

TWR Lighting, Inc. **MARK**[®]

Enlightened Technology[®]

4300 WINDFERN RD #100 - HOUSTON TX 77041-8943
VOICE (713) 973-6905 - FAX (713) 973-9352
web: www.twrlighting.com

IMPORTANT!!!

PLEASE TAKE THE TIME TO FILL OUT THIS FORM COMPLETELY. FILE IT IN A SAFE PLACE. IN THE EVENT YOU EXPERIENCE PROBLEMS WITH OR HAVE QUESTIONS CONCERNING YOUR CONTROLLER, THE FOLLOWING INFORMATION IS NECESSARY TO OBTAIN PROPER SERVICE AND PARTS.

MODEL # AA0M-TSS 48V DC

SERIAL # _____

PURCHASE DATE _____

PURCHASED FROM _____

TWR Lighting, Inc. **MARK** *Enlightened Technology*

AA0M-TSS 48V DC CONTROLLER

TABLE OF CONTENTS

1.0	GENERAL INFORMATION	1
2.0	INSTALLATION.....	2
2.1	MOUNTING THE CONTROL CABINET	2
2.2	EXTERNAL PHOTOCELL WIRING	2
2.3	POWER WIRING	3
2.4	OBSTRUCTION FIXTURE WIRING	3
2.5	OBSTRUCTION FIXTURE ALARM WIRING.....	3
3.0	THEORY OF OPERATION	5
3.1	POWER SUPPLY	5
3.2	OBSTRUCTION FIXTURE	5
4.0	MAINTENANCE GUIDE.....	6
4.1	RED OBSTRUCTION FIXTURE.....	6
4.2	CONTROLLER	6
4.3	PHOTOCELL	6
5.0	MAJOR COMPONENTS PARTS LIST	7
6.0	SUGGESTED SPARE PARTS LIST	8

WARRANTY & RETURN POLICY

RETURN MERCHANDISE AUTHORIZATION (RMA) FORM

TWR Lighting, Inc. **HARK**[®]

Enlightened Technology[®]

AA0M-TSS 48V DC CONTROLLER

APPENDIX

CHASSIS COMPONENT LAYOUT	1196-R (REV C)
SCHEMATIC LAYOUT	1196-S (REV B)
TROUBLESHOOTING FLOW CHART	1196-F
LIGHT KIT (CABLE).....	T-1128 (REV D)

TWR Lighting[®], Inc. HARK[®]

Enlightened Technology[®]

AA0M-TSS 48V DC CONTROLLER

1.0 GENERAL INFORMATION

The TWR Lighting[®], Inc. (TWR[®]) Model AA0M-TSS 48V DC Controller is for the application of one (1) LED double obstruction fixture.

The obstruction lights burn steady.

A by-pass switch (SW1) allows the controller to be turned on during daylight hours without covering the photocell. This is particularly helpful since the controller can be mounted indoors while the photocell is outdoors. SW1 can be operated by turning “on” the toggle switch mounted on the panel of the controller.

The photocell is the three (3) blade, twist to lock, type.

Power supplied to the controller shall be 48V DC.

Controller functions that are monitored by remote alarms in the form of dry contact closures (Form C) are as follows:

POWER FAILURE	Monitors 48V DC to the controller. Alarms in the event of power failure, or tripped circuit breaker.
LIGHTS “ON”	Gives an indication whenever the controller is activated.
OBSTRUCTION LIGHTS	Will give an alarm when one (1) of the two (2) lights in the double obstruction fixture fails.

TWR Lighting, Inc. **HARK**

Enlightened Technology®

AA0M-TSS 48V DC CONTROLLER

2.0 INSTALLATION

2.1 MOUNTING THE CONTROL CABINET

(Refer to Drawing 1196-R)

The power supply control cabinet can be located at the base of the structure or in an equipment building. Mounting footprints are shown on drawing 1196-R. Power wiring to the control cabinet should be in accordance with local methods and National Electrical Codes (NEC).

2.1.1 If the control cabinet is mounted inside an equipment building, the photocell should be mounted vertically on ½” conduit outside the building above the eaves facing north. Wiring from the photocell socket to the control cabinet should consist of one (1) each; red, black, and blue wires. The black wire is connected to the socket terminal marked “N,” the red wire is connected to the socket terminal marked “Li,” and the blue wire is connected to the socket terminal marked “Lo.” The photocell should be positioned so that it does not “see” ambient light, which would prevent it from switching to the nightmode.

2.1.2 If the control cabinet is mounted outside an equipment building, the photocell should be mounted vertically on ½” conduit so the photocell is above the control cabinet. Care must be taken to assure that the photocell does not “see” any ambient light that would prevent it from switching into the nightmode. The photocell wiring is the same as in 2.1.1.

The wiring from the photocell, the battery, and the sidelights should enter the control cabinet through the watertight connectors in the bottom of the cabinet. Inside the cabinet, the connections will be made on the terminal strips and circuit breaker located at the bottom of the chassis. These connections are made as follows:

2.2 EXTERNAL PHOTOCELL WIRING

(Refer to Drawing 1196-R)

2.2.1 Connect the **BLACK** wire from the photocell to terminal block TB2 marked “-.”

AA0M-TSS 48V DC CONTROLLER

2.2.2 Connect the **RED** wire from the photocell to terminal block TB2 marked “SSR.”

2.2.3 Connect the **BLUE** wire from the photocell to terminal block TB2 marked “+.”

2.3 POWER WIRING

(Refer to Drawing 1196-R)

2.3.1 Power wiring to the control cabinet should be in accordance with local methods and National Electrical Codes (NEC).

2.3.2 Connect the positive 48V DC to terminal block TB1 marked “+.”

2.3.3 Connect the negative wire to one (1) of the terminal blocks on TB1 marked “-.”

2.3.4 Connect the ground to the aluminum mounting plate.

2.4 OBSTRUCTION FIXTURE WIRING

(Refer to Drawing 1196-R)

2.4.1 Connect the **RED** from the double obstruction light to the circuit breaker marked “S.”

2.4.2 Connect the **BLACK** wire to the terminal block TB1 marked “-.”

2.4.3 Connect the ground to ground lug marked “G” inside the controller.

2.5 OBSTRUCTION FIXTURE ALARM WIRING

(Refer to Drawings 1196-R and 1196-S)

2.5.1 Alarm relays K1, K2, and Module M1 are provided for independent contact closures for: Power Failure, Lights “ON,” and Obstruction Fixture Burnout.

2.5.2 Alarm wiring: To utilize all of the obstruction fixture alarms, the customer will need three (3) pair of wires to interface with the alarm device.

TWR Lighting, Inc. HARK[®]

Enlightened Technology[®]

AA0M-TSS 48V DC CONTROLLER

Obstruction Fixture Burnout: Connect first wire from the first pair to Module M1, terminal #18, for normally open (or) terminal #16, for normally closed monitoring.

Connect second wire from the first pair to Module M1, terminal 15, for alarm common.

Power Failure Alarm: Connect first wire from the second pair to relay K1, terminal #3, for normally closed (or) terminal #4, for normally open monitoring.

Connect second wire from the second pair to relay K1, terminal #1.

Lights “ON” Alarm: Connect first wire from the third pair to relay K2, terminal #3, for normally closed (or) terminal #6, for normally open monitoring.

Connect second wire from the third pair to relay K2, terminal #1.

2.5.3 Testing: To test alarms, follow the procedures using the “ohm” meter between alarm common and alarm points.

Power Failure Open 48V DC circuit.

Lights “ON” Operate photocell by-pass switch (SW1) or cover the photocell.

Obstruction Fixture Trip circuit breaker on the controller panel.

TWR Lighting, Inc. HARK[®]

Enlightened Technology[®]

AA0M-TSS 48V DC CONTROLLER

3.0 THEORY OF OPERATION

3.1 POWER SUPPLY

48V AC enters the controller from the circuit breaker panel. Line sits at the 6589C-FAA photocell waiting to be switched and also keeps the power failure relay K1 energized. When the 6589C-FAA photocell is activated, line SSR energizes K2 “Lights On” relay. This can also be accomplished by using the photocell by-pass switch (SW1).

3.2 DOUBLE OBSTRUCTION LIGHTS

SSR is being sent to Module M1 and then to the circuit breaker “S.” Module M1 is the current sensor for the obstruction fixtures. If one (1) obstruction fixture burns out, then Module M1 will send contact obstruction fixture alarm on pin 16, or pin 18.

TWR Lighting, Inc. HARK[®]

Enlightened Technology[®]

AA0M-TSS 48V DC CONTROLLER

4.0 MAINTENANCE GUIDE

4.1 RED OBSTRUCTION FIXTURE

No scheduled maintenance is required. Perform on an as needed basis.

4.2 CONTROLLER

No scheduled maintenance is required. Perform on an as needed basis.

4.3 PHOTOCELL

The photocell is a sealed unit. No maintenance is needed or required other than replacement as necessary.

TWR Lighting, Inc. **HARK**[®]

Enlightened Technology[®]

AA0M-TSS 48V DC CONTROLLER

5.0 MAJOR COMPONENTS PARTS LIST

QTY	PART NUMBER	DESCRIPTION
1	6589C-FAA (This replaces the PCS48 photocell)	Photocell 12-48V DC
1	VJ1008HPL1X004	Enclosure
2	PB27E122	Octal Sockets (K1 and K2)
6	8WA1204	Terminal Blocks (TB1 and TB2)
1	S261-D1	1 amp Circuit Breaker (S)
2	8WA1808	End Stop
1	KRPA11DG48VDC	DPDT Relay (K1 and K2)
1	SSPIGTAIL	20' Photocell Pigtail
1	STJ01002	15 amp SPDT Switch (SW1)
1	RM4JA31MW	Current Sensor (M1)

TWR Lighting, Inc. **HARK**[®]

Enlightened Technology[®]

AA0M-TSS 48V DC CONTROLLER

6.0 SUGGESTED SPARE PARTS LIST

QTY	PART NUMBER	DESCRIPTION
1	6589C-FAA (This replaces the PCS48 photocell)	Photocell 12-48V DC
1	KRPA11DG48VDC	48V DC DPDT Relay

TWR Lighting[®], Inc. HARK[®]

Enlightened Technology[®]

AA0M-TSS 48V DC CONTROLLER

Warranty & Return Policy

TWR Lighting[®], Inc. (“TWR[®]”) warrants its products (other than “LED Product”) against defects in design, material (excluding incandescent bulbs) and workmanship for a period ending on the earlier of two (2) years from the date of shipment or one (1) year from the date of installation.

TWR Lighting[®], Inc. (“TWR[®]”) warrants its “LED Product” against defects in design, material and workmanship for a period of five (5) years from the date of shipment. TWR[®], at its sole option, will, itself, or through others, repair, replace or refund the purchase price paid for “LED Product” that TWR[®] verifies as being inoperable due to original design, material, or workmanship. All warranty replacement “LED Product” is warranted only for the remainder of the original warranty of the “LED Product” replaced. Replacement “LED Product” will be equivalent in function, but not necessarily identical, to the replaced “LED Product.”

TWR Lighting[®], Inc. (“TWR[®]”) warrants its “LED Product” against light degradation for a period of five (5) years from the date of installation. TWR[®], at its sole option, will, itself, or through others, repair, replace, or refund the purchase price paid for “LED Product” that TWR[®] verifies as failing to meet 75% of the minimum intensity requirements as defined in the FAA Advisory Circular 150/5345-43G dated 09/26/12. All warranty replacement “LED Product” is warranted only for the remainder of the original warranty of the “LED Product” replaced. Replacement “LED Product” will be equivalent in function, but not necessarily identical, to the replaced “LED Product.”

Replacement parts (other than “LED Product”) are warranted for 90 days from the date of shipment.

Conditions not covered by this Warranty, or which might **void** this Warranty are as follows:

- x Improper Installation or Operation
- x Misuse
- x Abuse
- x Unauthorized or Improper Repair or Alteration
- x Accident or Negligence in Use, Storage, Transportation, or Handling
- x Any Acts of God or Nature
- x **Non-OEM Parts**

The use of Non-OEM parts or modifications to original equipment design will void the manufacturer warranty and could invalidate the assurance of complying with FAA requirements as published in Advisory Circular 150/5345-43.

TWR Lighting, Inc. **HARK**[®]

Enlightened Technology[®]

AA0M-TSS 48V DC CONTROLLER

Warranty & Return Policy (continued)

Field Service – Labor, Travel, and Tower Climb are not covered under warranty. Customer shall be obligated to pay for all incurred charges. An extensive network of certified and insured Service Representatives is available if requested.

Return Terms – You must first contact our Customer Service Department at **713-973-6905** to acquire a Return Merchandise Authorization (RMA) number in order to return the product(s). Please have the following information available when requesting an RMA number:

- x The contact name and phone number of the tower owner
- x The contact name and phone number of the contractor
- x The site name and number
- x The part number(s)
- x The serial number(s) (if any)
- x A description of the problem
- x The billing information
- x The Ship To address

This RMA number must be clearly visible on the outside of the box. If the RMA number is not clearly labeled on the outside of the box, your shipment will be refused. Please ensure the material you are returning is packaged carefully. **The warranty is null and void if the product(s) are damaged in the return shipment.**

All RMAs must be received by TWR LIGHTING[®], INC., 4300 WINDFERN RD #100, HOUSTON TX 77041-8943, within 30 days of issuance.

Upon full compliance with the Return Terms, TWR[®] will replace, repair and return, or credit product(s) returned by the customer. It is TWR[®]'s sole discretion to determine the disposition of the returned item(s).

TWR Lighting, Inc. **HARK**[®]

Enlightened Technology[®]

AA0M-TSS 48V DC CONTROLLER

Warranty & Return Policy (continued)

Replacements – Replacement part(s) will be shipped and billed to the customer for product(s) considered as Warranty, pending return of defective product(s). When available, a certified reconditioned part is shipped as warranty replacement with a Return Merchandise Authorization (RMA) number attached. Upon receipt of returned product(s), inspection, testing, and evaluation will be performed to determine the cause of defect. The customer is then notified of the determination of the testing.

- x Product(s) that is deemed defective and/or unrepairable and covered under warranty - a credit will be issued to the customer's account.
- x Product(s) found to have no defect will be subject to a **\$75.00 per hour testing charge (1 hour minimum), which will be invoiced to the customer.** At this time the customer may decide to have the tested part(s) returned and is responsible for the return charges.
- x Product(s) under warranty, which the customer does not wish returned, the customer will be issued a credit against the replacement invoice.

Repair & Return – A Return Merchandise Authorization (RMA) will be issued for all part(s) returned to TWR[®] for repair. Upon receipt of returned product(s), inspection, testing, and evaluation will be performed to determine the cause of defect. The customer is then notified of the determination of the testing. If the returned part(s) is deemed unrepairable, or the returned part(s) is found to have no defect, the customer will be subject to a **\$75.00 per hour testing charge (1 hour minimum), which will be invoiced to the customer.** Should the returned parts be determined to be repairable, a written estimated cost of repair will be sent to the customer for their written approval prior to any work being performed. In order to have the tested part(s) repaired and/or returned, the customer must issue a purchase order and is responsible for the return shipping charges.

Return to Stock – Any order that is returned to TWR[®] for part(s) ordered incorrectly by the customer, or unneeded upon receipt, the customer is required to pay a **20% restocking fee.** A credit will be issued once it is determined that the Return Terms are met.

Credits – Credits are issued once it is determined that all of the Warranty and Return Terms are met. All credits are processed on Fridays. In the event a Friday falls on a Holiday, the credit will be issued on the following Friday.

Freight – All warranty replacement part(s) will be shipped via ground delivery and paid for by TWR[®]. Delivery other than ground is the responsibility of the customer.

TWR Lighting, Inc. **MARK**[®]

Enlightened Technology[®]

AA0M-TSS 48V DC CONTROLLER

Warranty & Return Policy (continued)

REMEDIES UNDER THIS WARRANTY ARE LIMITED TO PROVISIONS OF REPLACEMENT PARTS AND REPAIRS AS SPECIFICALLY PROVIDED. IN NO EVENT SHALL TWR[®] BE LIABLE FOR ANY OTHER LOSSES, DAMAGES, COSTS, OR EXPENSES INCURRED BY THE CUSTOMER, INCLUDING, BUT NOT LIMITED TO, LOSS FROM FAILURE OF THE PRODUCT(S) TO OPERATE FOR ANY TIME, AND ALL OTHER DIRECT, INDIRECT, SPECIAL, INCIDENTAL, OR CONSEQUENTIAL DAMAGES, INCLUDING ALL PERSONAL INJURY OR PROPERTY DAMAGE DUE TO ALLEGED NEGLIGENCE, OR ANY OTHER LEGAL THEORY WHATSOEVER. THIS WARRANTY IS MADE BY TWR[®] EXPRESSLY IN LIEU OF ALL OTHER WARRANTIES, WHETHER EXPRESSED OR IMPLIED. WITHOUT LIMITING THE GENERALITY OF THE FORGOING, TWR[®] MAKES NO WARRANTY OF MERCHANTABILITY OR FITNESS OF THE PRODUCT(S) FOR ANY PARTICULAR PURPOSE. TWR[®] EXPRESSLY DISCLAIMS ALL OTHER WARRANTIES.

TWR Lighting, Inc. **HARK**[®]

Enlightened Technology[®]

AA0M-TSS 48V DC CONTROLLER

RETURN MERCHANDISE AUTHORIZATION (RMA) FORM

RMA#: _____ **DATE:** _____

CUSTOMER: _____

CONTACT: _____ **PHONE NO.:** _____

ITEM DESCRIPTION (PART NO.): _____

MODEL NO.: _____ **SERIAL NO.:** _____

ORIGINAL TWR INVOICE NO.: _____ **DATED:** _____

DESCRIPTION OF PROBLEM: _____

SIGNED: _____ **DATE NEEDED:** _____

RETURN ADDRESS: _____

PLEASE RETURN PRODUCT TO: 4300 WINDFERN RD #100 HOUSTON TX 77041-8943

TWR Lighting, Inc. HARK[®]

Enlightened Technology[®]

AA0M-TSS 48V DC CONTROLLER

RETURN MERCHANDISE AUTHORIZATION (RMA) FORM

RMA#: _____ **DATE:** _____

CUSTOMER: _____

CONTACT: _____ **PHONE NO.:** _____

ITEM DESCRIPTION (PART NO.): _____

MODEL NO.: _____ **SERIAL NO.:** _____

ORIGINAL TWR INVOICE NO.: _____ **DATED:** _____

DESCRIPTION OF PROBLEM: _____

SIGNED: _____ **DATE NEEDED:** _____

RETURN ADDRESS: _____

PLEASE RETURN PRODUCT TO: 4300 WINDFERN RD #100 HOUSTON TX 77041-8943

*CUSTOMER ALARM POINTS

- OLNC = OBSTRUCTION LIGHT ALARM (NORMALLY CLOSED)
- OLNO = OBSTRUCTION LIGHT ALARM (NORMALLY OPEN)
- C = ALARM COMMON
- LO = LIGHTS "ON" INDICATOR
- PFNC = POWERFAIL (NORMALLY CLOSED)
- PFNO = POWERFAIL (NORMALLY OPENED)

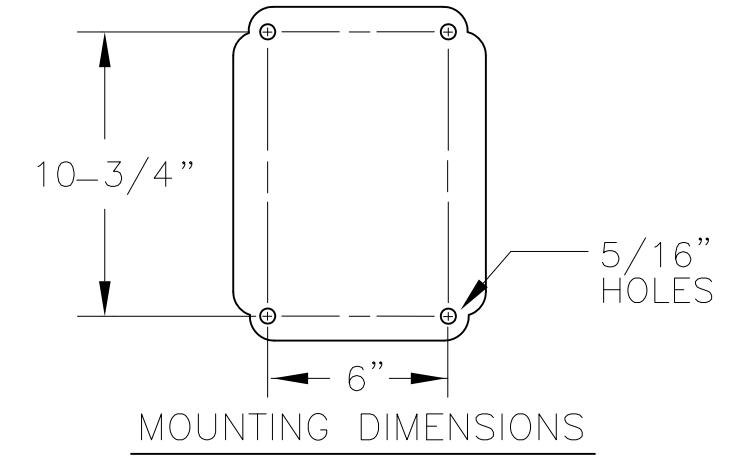

NOTES:

1. PLUG 6589C-FAA PHOTOCELL INTO 43109 TWIST LOCK RECEPTACLE AND TWIST TO LOCK.
2. WIRES ARE CONNECTED LETTER TO LETTER. (EXAMPLE) S TO S...

9"X7" PLATE

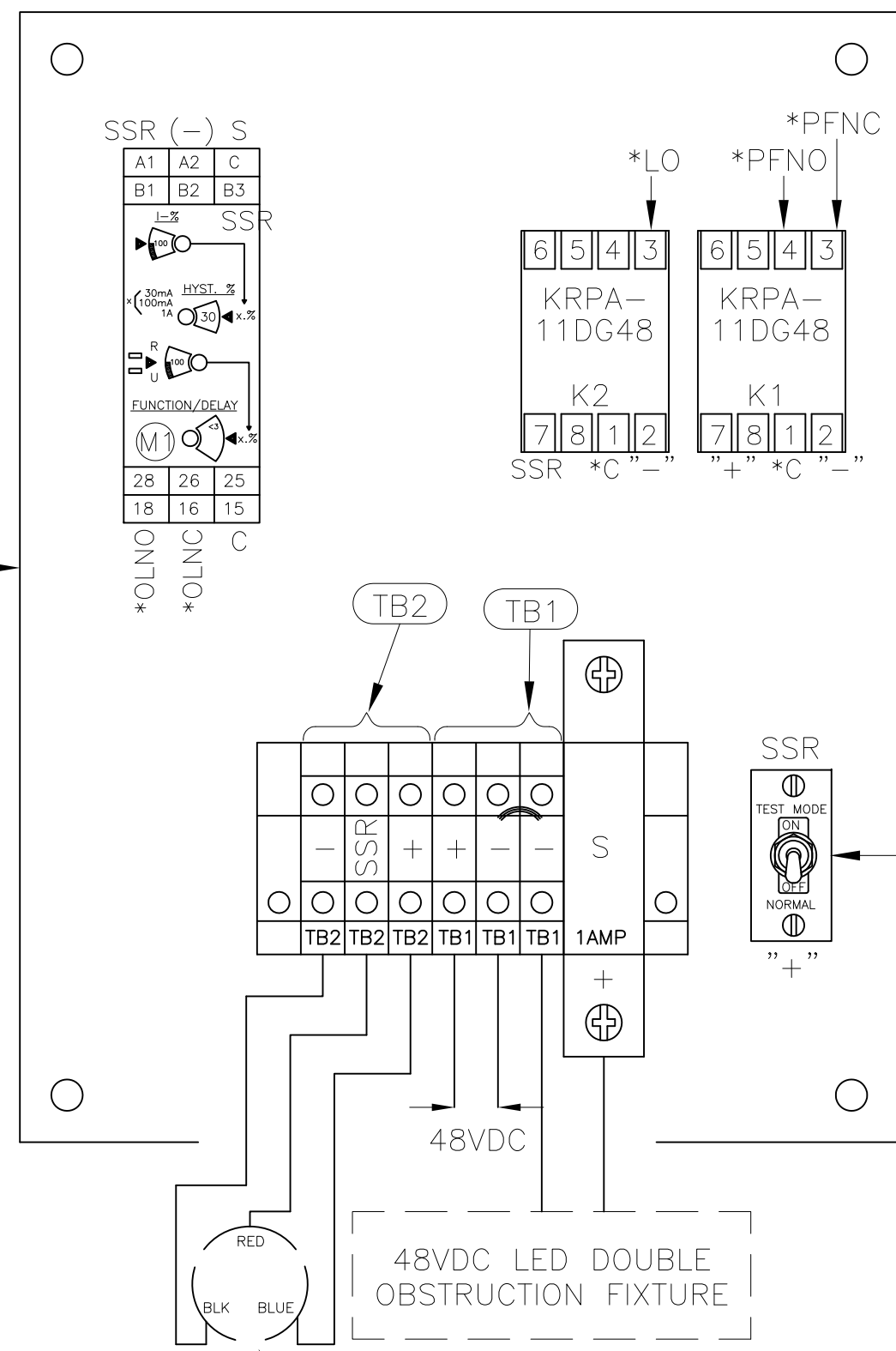

<u>AAOM-TSS 48VDC</u> <u>CHASSIS LAYOUT</u>			
PROD DEPT	TWR Lighting, Inc. <i>Enlightened Technology</i>		
SERV DEPT			
ENGINEER			
DRAWN BY E.A.SALAZAR	SHEET SIZE B	SHEET QTY. 1 OF 1	
DATE 05/27/2004	SCALE N.T.S.	DWG. NO. 1196-R	
<small>The use of non-OEM parts or modifications to original equipment design will void the manufacturer warranty and could invalidate the assurance of complying with FAA requirements as published in Advisory Circular 150/5345-43. NOTICE: The drawings and photographic images contained herein are the sole property of TWR Lighting, Inc. All information contained herein that is not generally known shall be considered confidential except to the extent the information has been previously established. The drawings and photographic images contained herein may not be reproduced, copied or used as the basis for manufacture or sale or promotion or any other purpose without the expressed written permission of TWR Lighting, Inc.</small>			

09/28/11	(C)	ADDED + TO S
DATE:	LTR.	REVISION

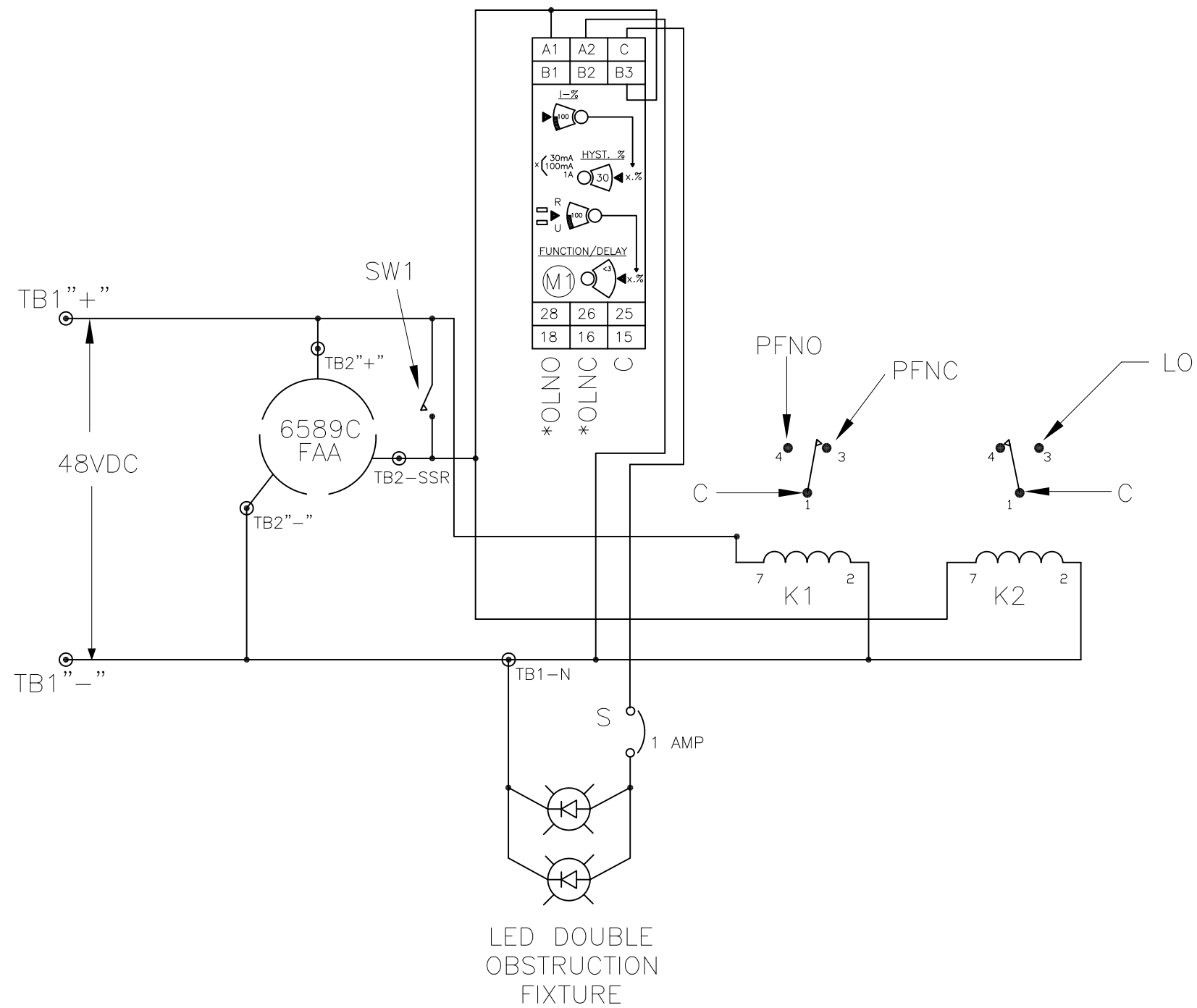

AAOM-TSS 48VDC SCHEMATIC LAYOUT			
APP'D	TWR Lighting, Inc. <i>Enlightened Technology</i>		
CHK'D BY			
ENGINEER			
DRAWN BY E.A.SALAZAR	SHEET SIZE B	SHEET QTY. 1 OF 1	
DATE 05/27/04	SCALE N.T.S.	DWG. NO. 1196-S	
08/11/08	(B) E.A.S.	CHG. PHOTOCELL	
DATE:	LTR.	REVISION	

The use of non-OEM parts or modifications to original equipment design will void the manufacturer warranty and could invalidate the assurance of complying with FAA requirements as published in Advisory Circular 150/5345-43.
NOTICE: The drawings and photographic images contained herein are the sole property of TWR Lighting, Inc. All information contained herein that is not generally known shall be considered confidential except to the extent the information has been previously established. The drawings and photographic images contained herein may not be reproduced, copied or used as the basis for manufacture or sale or promotion or any other purpose without the expressed written permission of TWR Lighting, Inc.

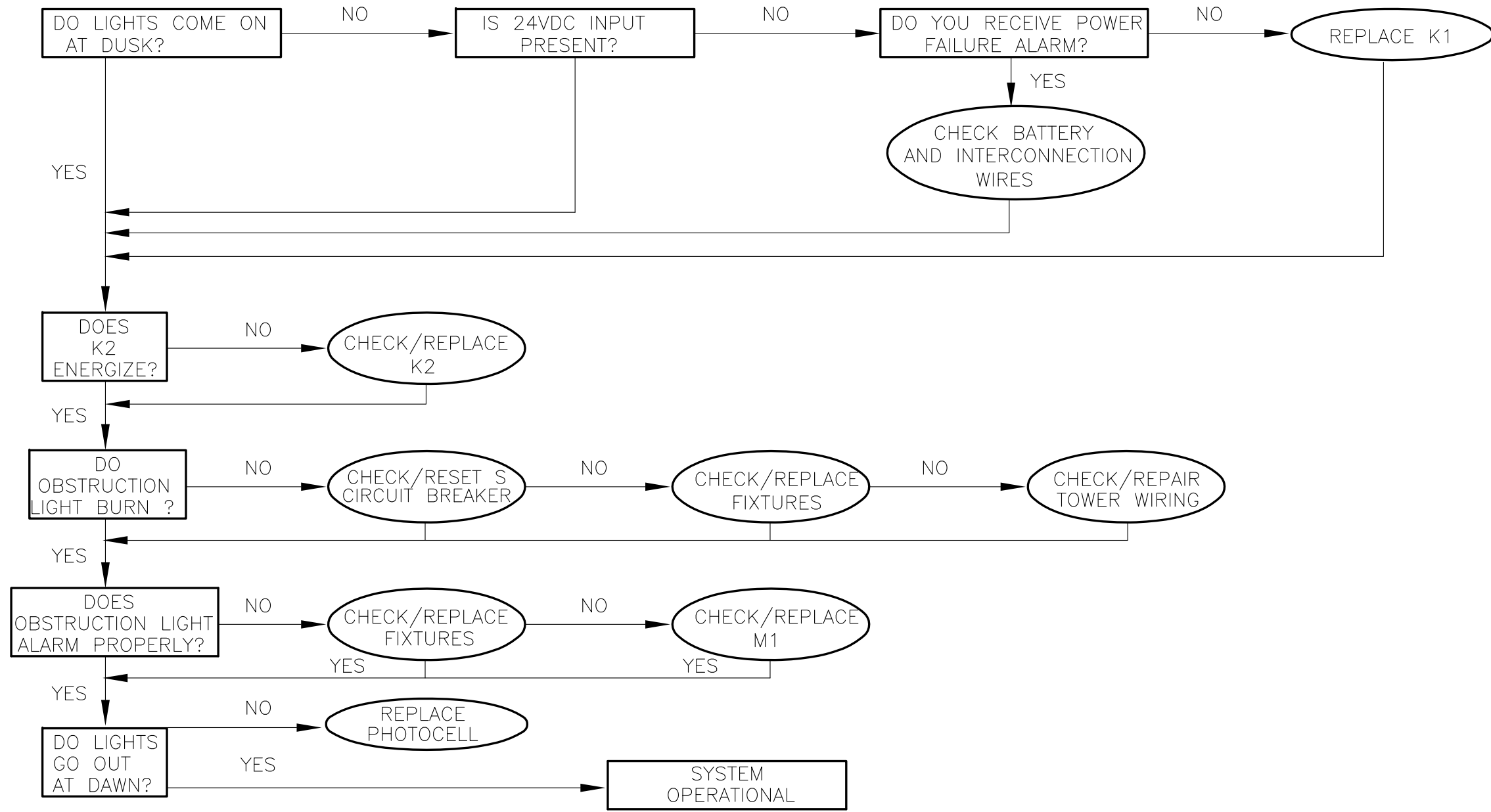

**AAOM-TSS 48VDC TROUBLESHOOTING
FLOW CHART**

APP'D	TWR Lighting, Inc. <i>Enlightened Technology</i>		
CHK'D BY			
ENGINEER			
DRAWN BY E.A.SALAZAR	SHEET SIZE B	SHEET QTY. 1 OF 1	
DATE 07/07/05	SCALE N.T.S.	DWG. NO. 1196-F	

The use of non-OEM parts or modifications to original equipment design will void the manufacturer warranty and could invalidate the assurance of complying with FAA requirements as published in Advisory Circular 150/5345-43.
NOTICE: The drawings and photographic images contained herein are the sole property of TWR Lighting, Inc. All information contained herein that is not generally known shall be considered confidential except to the extent the information has been previously established. The drawings and photographic images contained herein may not be reproduced, copied or used as the basis for manufacture or sale or promotion or any other purpose without the expressed written permission of TWR Lighting, Inc.

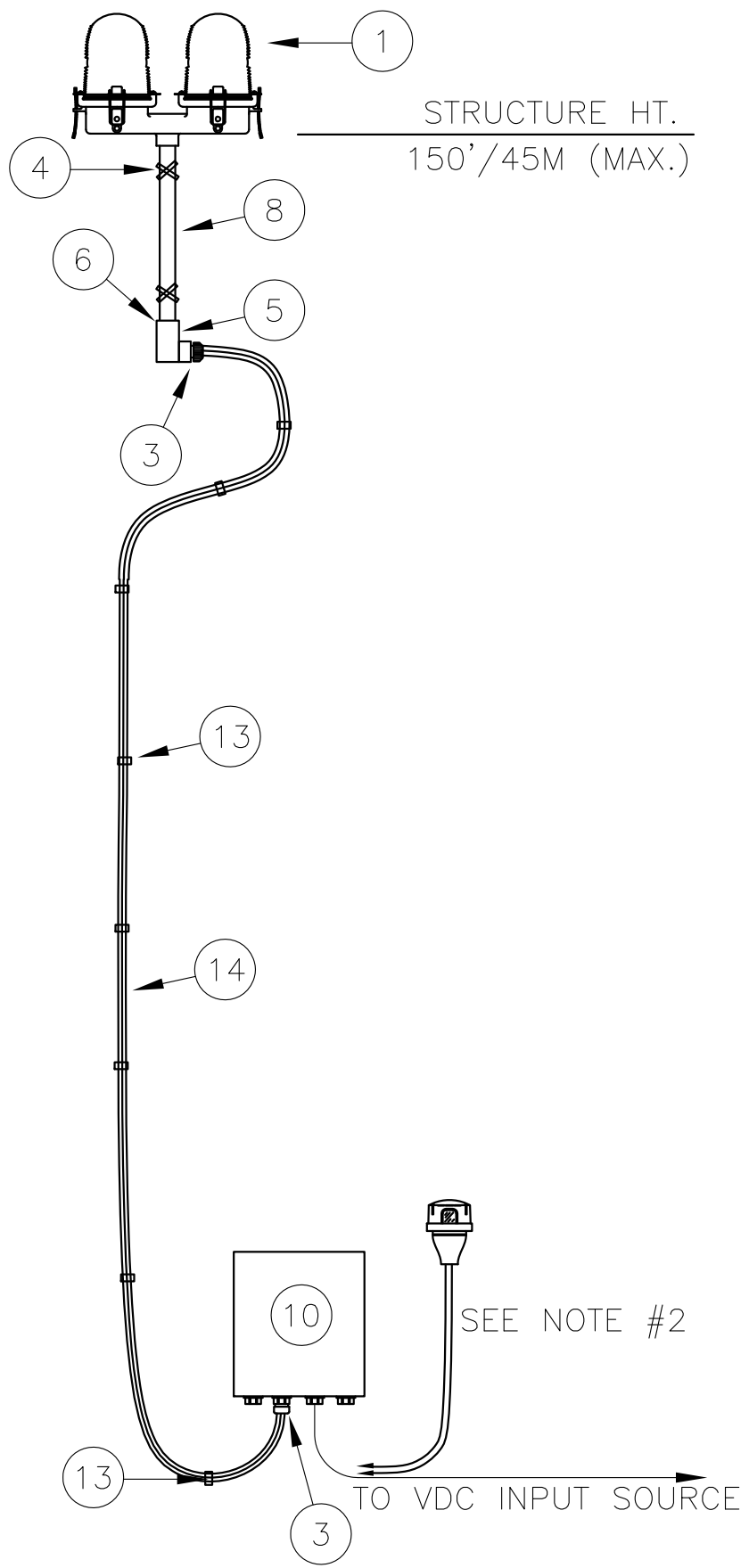

STRUCTURE HT.
150'/45M (MAX.)

SEE NOTE #2
TO VDC INPUT SOURCE

TOWER WIRING AND ASSEMBLY

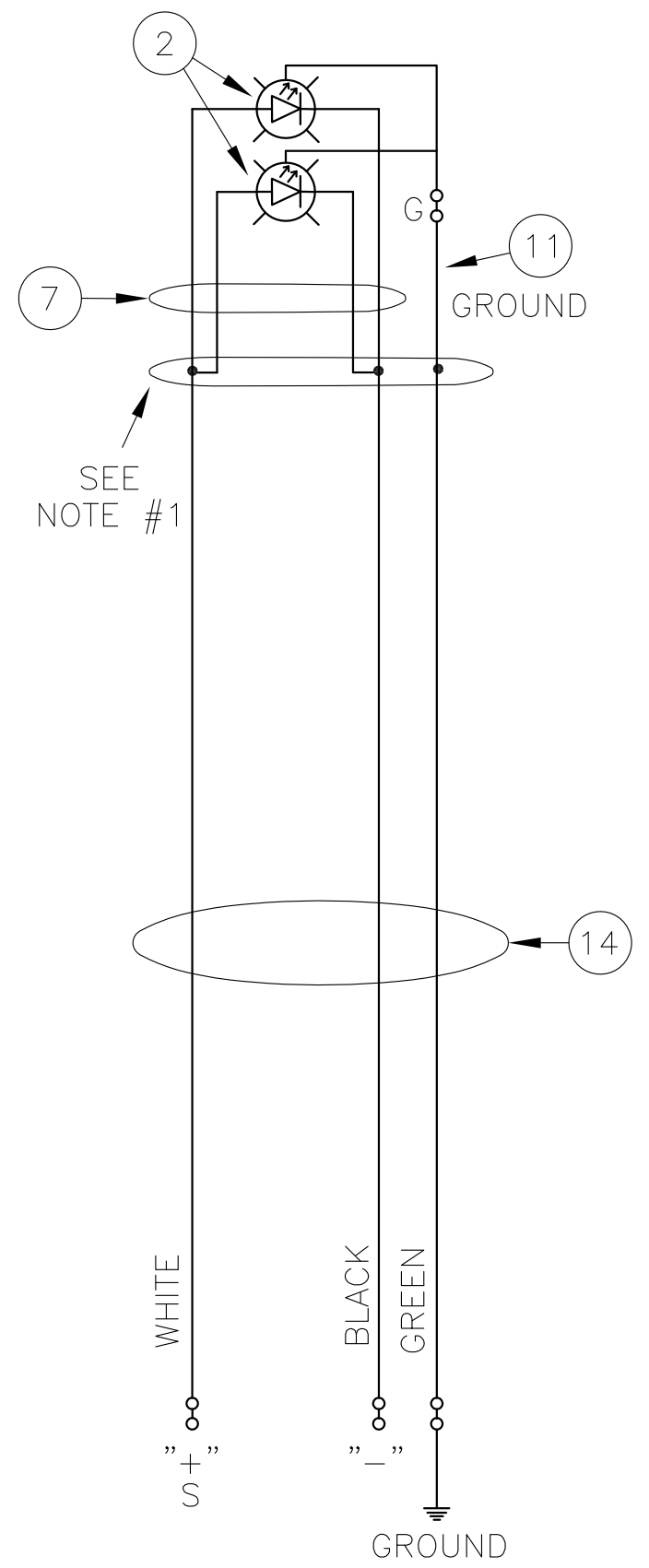

SEE NOTE #1

WHITE
" + "
BLACK
" - "
GREEN
GROUND

BILL OF MATERIALS

ITEM NO.	QTY.	TWR PART NO.	DESCRIPTION
1	1	OL2-LED	LED DOUBLE SIDELIGHT 3/4 INCH
2	--	---	---
3	2	CGB295SA	3/4" CORD CONNECTOR .5-.62
4	1	SS5012	WRAPLOCK 50'
5	1	TL27CG	L CONDULET W/COVER & GASKET
6	2	A314	3/4" CONDUIT LOCKNUTS
7	1	OL2PIGTAILG	18" OL2 PIGTAIL WITH GROUND
8	1	N34T12	3/4" X 12" NIPPLE
*	6	WIRENUTRED	RED WIRE NUT
10	1	AA0-MLED	AA0-MLED CONTROLLER
*	12	TAPEL1	BLACK ELECTRICAL TAPE
13	--	STCABLTIE	CABLE TIES (TWR. HT. ÷ 5)
14	--	CS012/3	3-#12 AWG CABLE (TWR. HT.+ 30')

* = NOT SHOWN

NOTES:

- 1) USE TWR PART #WIRENUTRED AND TAPEL1 TO CONNECT CS012/3 WIRE TO OL2PIGTAILG IN THE TL27CG.
- 2) PHOTOCELL AND PIGTAIL PROVIDED WITH CONTROLLER. PHOTOCELL IS TO BE MOUNTED OUTDOORS TEEING OF CONDUIT RUN TO BREAKER BOX.
- 3) CABLE RUN NOT TO EXCEED 300'.

DC

AA0-MLED LIGHTING KIT W/ CABLE

PROD DEPT	TWR Lighting, Inc. <i>Enlightened Technology</i> MARK		
SERV DEPT			
ENGINEER			
DRAWN BY E.A.SALAZAR	SHEET SIZE B	SHEET QTY. 1 OF 1	DWG. NO. T1128
DATE 03/04/03	SCALE N.T.S.		

The use of non-OEM parts or modifications to original equipment design will void the manufacturer warranty and could invalidate the assurance of complying with FAA requirements as published in Advisory Circular 150/5345-43.
NOTICE: The drawings and photographic images contained herein are the sole property of TWR Lighting, Inc. All information contained herein that is not generally known shall be considered confidential except to the extent the information has been previously established. The drawings and photographic images contained herein may not be reproduced, copied or used as the basis for manufacture or sale or promotion or any other purpose without the expressed written permission of TWR Lighting, Inc.

01/14/2015	D	UPDATED DRAWING
DATE:	LTR.	REVISION