

TWR Lighting, Inc.

Enlightened TechnologySM

4300 WINDFERN RD #100 – HOUSTON TX 77041-8943

VOICE (713) 973-6905 – FAX (713) 973-9352

web: twrlighting.com

IMPORTANT!!!

PLEASE TAKE THE TIME TO FILL OUT THIS FORM COMPLETELY. FILE IT IN A SAFE PLACE. IN THE EVENT YOU EXPERIENCE PROBLEMS WITH, OR HAVE QUESTIONS CONCERNING YOUR CONTROLLER, THE FOLLOWING INFORMATION IS NECESSARY TO OBTAIN PROPER SERVICE AND PARTS.

MODEL # OL2TR-230V

SERIAL # _____

PURCHASE DATE _____

PURCHASED FROM _____

TWR Lighting, Inc.

Enlightened TechnologySM

OL2TR-230V CONTROLLER

TABLE OF CONTENTS

GENERAL INFORMATION	1
SUGGESTED SPARE PARTS LIST	2
WARRANTY & RETURN POLICY	
RETURN MERCHANDISE AUTHORIZATION (RMA) FORM	

TWR Lighting, Inc.

Enlightened TechnologySM

OL2TR-230V CONTROLLER

APPENDIX

CHASSIS LAYOUT	100399
L-810 OL-2 DOUBLE OBSTRUCTION LIGHT	FM10020
L-810 OL-2 ASSEMBLY DETAI	310 (Rev. A)
SIDELIGHT RECEPTACLE WIRING.....	274-S (Rev. A)
JUNCTION AND STRAIN RELIEF BOXES	100089 (Rev. A)

TWR Lighting, Inc.

Enlightened TechnologySM

OL2TR-230V CONTROLLER

GENERAL INFORMATION

A0 lighting is for towers up to 150' above ground level (AGL). An OL-2 fixture is already installed with this controller.

One (1) bulb within the OL-2 fixture will burn steady. When the main lamp extinguishes, the secondary lamp will light.

Wiring connections for service power and tower wiring can be found on Drawing 100399, which is included in this manual.

TWR Lighting, Inc.

Enlightened TechnologySM

OL2TR-230V CONTROLLER

SUGGESTED SPARE PARTS LIST

QUANTITY	PART NUMBER	DESCRIPTION
1	9KE – 1 Lamp 240V	Lamp Burnout Detector

TWR Lighting, Inc.

Enlightened TechnologySM

Warranty & Return Policy

TWR Lighting, Inc. (“TWR”) warrants its products (other than “LED Product”) against defects in design, material (excluding incandescent bulbs) and workmanship for a period ending on the earlier of two (2) years from the date of shipment or one (1) year from the date of installation.

TWR Lighting, Inc. (“TWR”) warrants its “LED Product” against defects in design, material and workmanship for a period of five (5) years from the date of shipment. TWR, at its sole option, will, itself, or through others, repair, replace or refund the purchase price paid for “LED Product” that TWR verifies as being inoperable due to original design, material or workmanship. All warranty replacement “LED Product” is warranted only for the remainder of the original warranty of the “LED Product” replaced. Replacement “LED Product” will be equivalent in function, but not necessarily identical, to the replaced “LED Product.”

TWR Lighting, Inc. (“TWR”) warrants its “LED Product” against light degradation for a period of five (5) years from the date of installation. TWR, at its sole option, will, itself, or through others, repair, replace or refund the purchase price paid for “LED Product” that TWR verifies as failing to meet 70% of the minimum intensity requirements as defined in the FAA Advisory Circular 150/5345-43E dated 10/19/95. All warranty replacement “LED Product” is warranted only for the remainder of the original warranty of the “LED Product” replaced. Replacement “LED Product” will be equivalent in function, but not necessarily identical, to the replaced “LED Product.”

Replacement parts (other than “LED Product”) are warranted for 90 days from the date of shipment.

Conditions not covered by this Warranty, or which might void this Warranty are as follows:

- Improper Installation or Operation
- Misuse
- Abuse
- Unauthorized or Improper Repair or Alteration
- Accident or Negligence in Use, Storage, Transportation, or Handling
- Any Acts of God or Nature
- **Non-OEM Parts**

The use of non-OEM parts or modifications to original equipment design will void the manufacturer warranty and could invalidate the assurance of complying with FAA requirements as published in Advisory Circular 150/5345-43.

Field Service – Repairs are warranted for 90 days from the date of service, except where TWR has made recommendations that were not adhered to that may cause premature failure on previous repairs. Labor, Travel, and Tower Climb are not covered under warranty. Customer shall be obligated to pay for all incurred charges not related to warranty. All warranty repairs are performed

by trained TWR personnel, or dispatched through an extensive network of certified and insured Service Representatives.

Warranty & Return Policy

(continued)

Return Policy

Return Terms – You must first contact our Customer Service Department at **713-973-6905** to acquire a Return Merchandise Authorization (RMA) number in order to return the product(s). Please have the following information available when requesting an RMA number:

- The contact name and phone number of the tower owner
- The contact name and phone number of the contractor
- The site name and number
- The part number(s)
- The serial number(s) (if any)
- A description of the problem
- The billing information
- The Ship To address

This RMA number must be clearly visible on the outside of the box. If the RMA number is not clearly labeled on the outside of the box, your shipment will be refused. Please ensure the material you are returning is packaged carefully. **The warranty is null and void if the product(s) are damaged in the return shipment.**

All RMAs must be received by TWR LIGHTING, INC., 4300 WINDFERN RD #100, HOUSTON TX 77041-8943, within 30 days of issuance.

Upon full compliance with the Return Terms, TWR will replace, repair and return, or credit product(s) returned by the customer. It is TWR's sole discretion to determine the disposition of the returned item(s).

Replacements – Replacement part(s) will be shipped and billed to the customer for product(s) considered as Warranty, pending return of defective product(s). When available, a certified reconditioned part is shipped as warranty replacement with a Return Merchandise Authorization (RMA) number attached. Upon receipt of returned product(s), inspection, testing, and evaluation will be performed to determine the cause of defect. The customer is then notified of the determination of the testing.

- Product(s) that is deemed defective and/or unrepairable and covered under warranty - a credit will be issued to the customer's account.
- Product(s) found to have no defect will be subject to a **\$60.00 per hour testing charge (1 hour minimum), which will be invoiced to the customer.** At this time the customer may decide to have the tested part(s) returned and is responsible for the return charges.
- Product(s) under warranty, which the customer does not wish returned, the customer will be issued a credit against the replacement invoice.

Warranty & Return Policy

(continued)

Repair & Return – A Return Merchandise Authorization (RMA) will be issued for all part(s) returned to TWR for repair. Upon receipt of returned product(s), inspection, testing and evaluation will be performed to determine the cause of defect. The customer is then notified of the determination of the testing. If the returned part(s) is deemed unrepairable, or the returned part(s) is found to have no defect, the customer will be subject to a **\$60.00 per hour testing charge (1 hour minimum), which will be invoiced to the customer.** Should the returned parts be determined to be repairable, a written estimated cost of repair will be sent to the customer for their written approval prior to any work being performed. In order to have the tested part(s) repaired and/or returned, the customer must issue a purchase order and is responsible for the return shipping charges.

Return to Stock – Any order that is returned to TWR for part(s) ordered incorrectly by the customer, or unneeded upon receipt, the customer is required to pay a **20% restocking fee.** A credit will be issued once it is determined that the Return Terms are met.

Credits – Credits are issued once it is determined that all of the Warranty and Return Terms are met. All credits are processed on Fridays. In the event a Friday falls on a Holiday, the credit will be issued on the following Friday.

Freight – All warranty replacement part(s) will be shipped via ground delivery and paid for by TWR. Delivery other than ground is the responsibility of the customer.

REMEDIES UNDER THIS WARRANTY ARE LIMITED TO PROVISIONS OF REPLACEMENT PARTS AND REPAIRS AS SPECIFICALLY PROVIDED. IN NO EVENT SHALL TWR BE LIABLE FOR ANY OTHER LOSSES, DAMAGES, COSTS OR EXPENSES INCURRED BY THE CUSTOMER, INCLUDING, BUT NOT LIMITED TO, LOSS FROM FAILURE OF THE PRODUCT(S) TO OPERATE FOR ANY TIME, AND ALL OTHER DIRECT, INDIRECT, SPECIAL, INCIDENTAL, OR CONSEQUENTIAL DAMAGES, INCLUDING ALL PERSONAL INJURY OR PROPERTY DAMAGE DUE TO ALLEGED NEGLIGENCE, OR ANY OTHER LEGAL THEORY WHATSOEVER. THIS WARRANTY IS MADE BY TWR EXPRESSLY IN LIEU OF ALL OTHER WARRANTIES, WHETHER EXPRESSED OR IMPLIED. WITHOUT LIMITING THE GENERALITY OF THE FORGOING, TWR MAKES NO WARRANTY OF MERCHANTABILITY OR FITNESS OF THE PRODUCT(S) FOR ANY PARTICULAR PURPOSE. TWR EXPRESSLY DISCLAIMS ALL OTHER WARRANTIES.

TWR Lighting, Inc.

Enlightened TechnologySM

RETURN MERCHANDISE AUTHORIZATION (RMA) FORM

RMA#: _____ DATE: _____

CUSTOMER: _____

CONTACT: _____ PHONE NO.: _____

ITEM DESCRIPTION (PART NO.): _____

MODEL NO.: _____ SERIAL NO.: _____

ORIGINAL TWR INVOICE NO.: _____ DATED: _____

DESCRIPTION OF PROBLEM: _____

SIGNED: _____ DATE NEEDED: _____

RETURN ADDRESS: _____

TWR Lighting, Inc.

Enlightened TechnologySM

RETURN MERCHANDISE AUTHORIZATION (RMA) FORM

RMA#: _____ DATE: _____

CUSTOMER: _____

CONTACT: _____ PHONE NO.: _____

ITEM DESCRIPTION (PART NO.): _____

MODEL NO.: _____ SERIAL NO.: _____

ORIGINAL TWR INVOICE NO.: _____ DATED: _____

DESCRIPTION OF PROBLEM: _____

SIGNED: _____ DATE NEEDED: _____

RETURN ADDRESS: _____

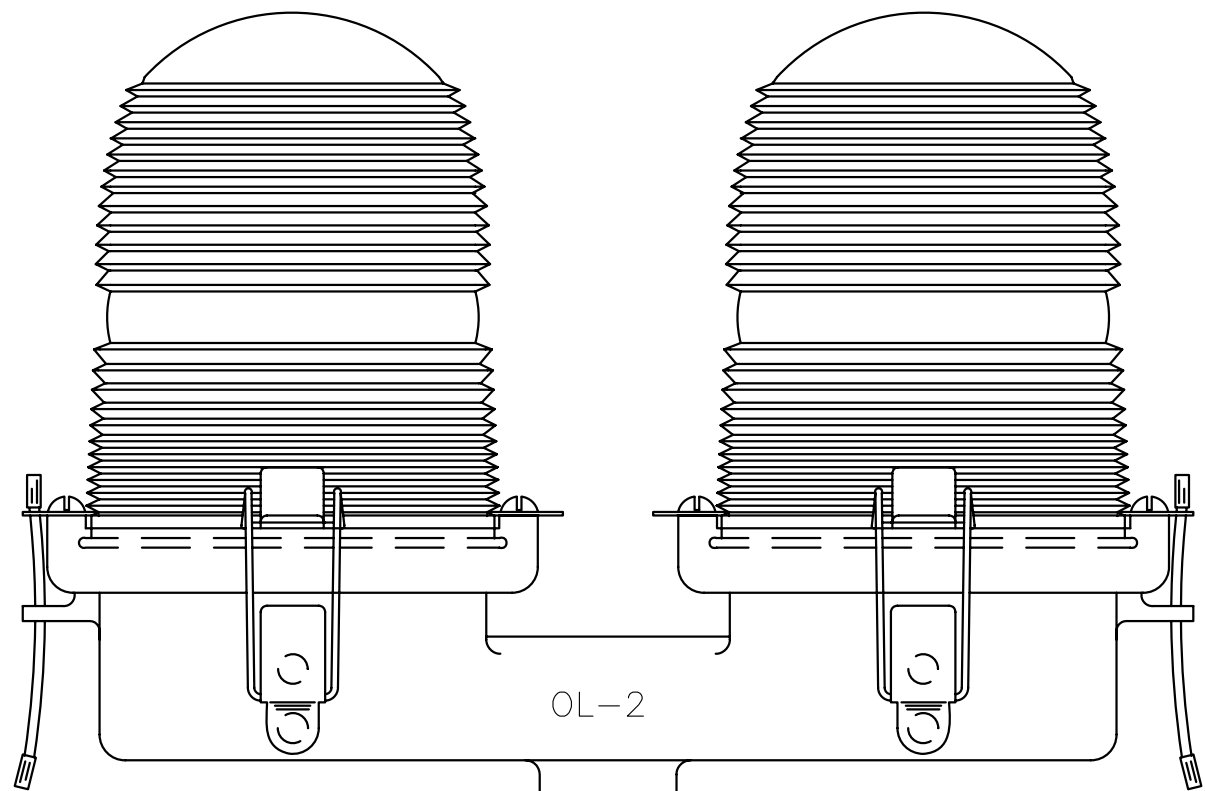

4" NIPPLE →
 → 2-3/4" CONDUIT NUT

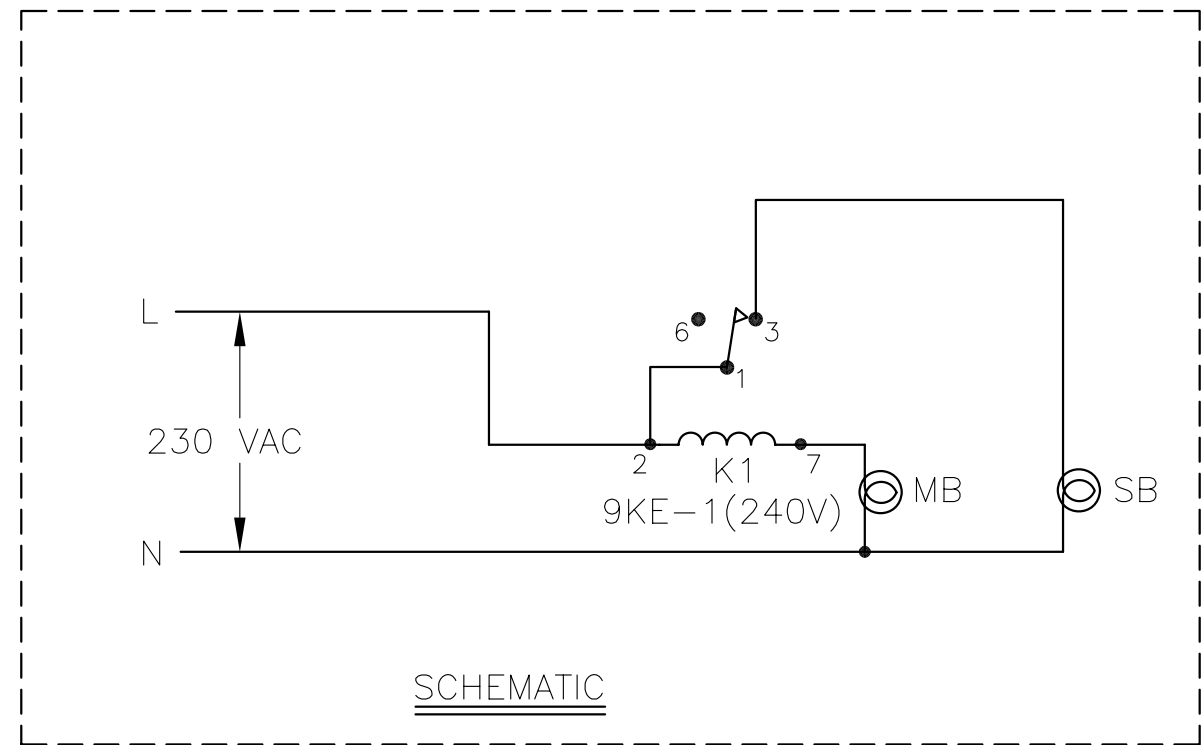
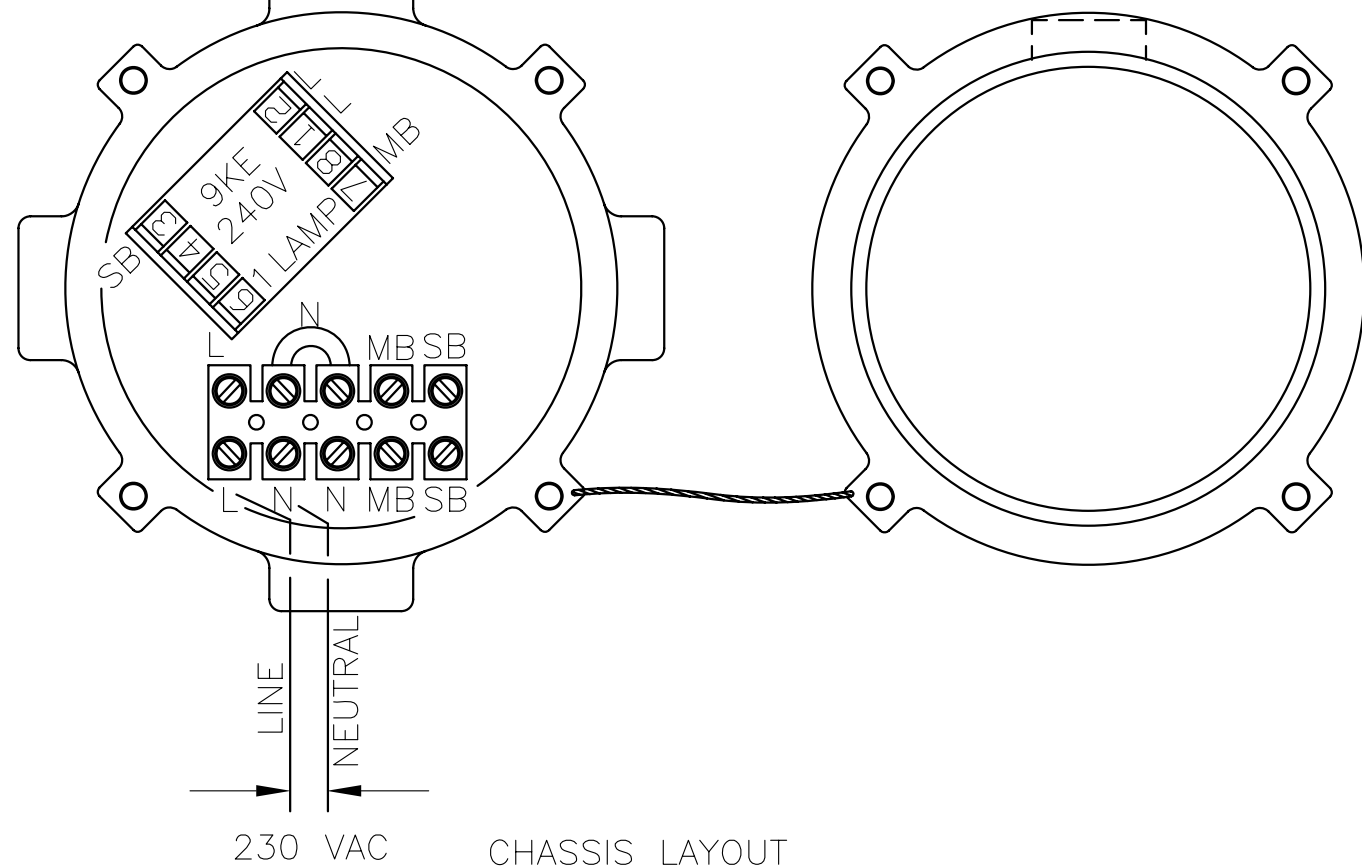

NOTE:

- 1) WIRES ARE CONNECTED LETTER TO LETTER.
(EXAMPLE) L TO L.
- 2) LAMPS - 116W 230V
- 3) MB = MAIN BULB
SB = SPARE BULB

OL2TR 230V CONTROLLER

TWR Lighting, Inc.

APP'D	ENGINEER	CHK'D BY
DRAWN BY E.A.SALAZAR		SHEET SIZE B
DATE 11/17/97	SCALE N.T.S.	SHEET QTY. 1 OF 1
		DWG. NO. 100399

The use of non-OEM parts or modifications to original equipment design will void the manufacturer warranty and could invalidate the assurance of complying with FAA requirements as published in Advisory Circular 150/5345-43.
 NOTICE: This drawing is the property of TWR Lighting, Inc. All information contained herein that is not generally known shall be confidential except to the extent the information has been previously established. This drawing may not be reproduced, copied or used as the basis for manufacture or sale without written permission.

TWR Lighting, Inc.

FAA Approved L-810 Double Obstruction Light OL2

FM10020RD.DWG

For use as an obstruction light on towers, buildings, etc. ETL approved to meet or exceed all FAA specifications as found in AC 150/5345-43 Type L-810.

When used with our AOXFR controller, when one bulb burns out, the unit automatically switches to backup bulb.

High temperature ultra pure
FAA approved aviation red, blue
yellow and clear lenses.

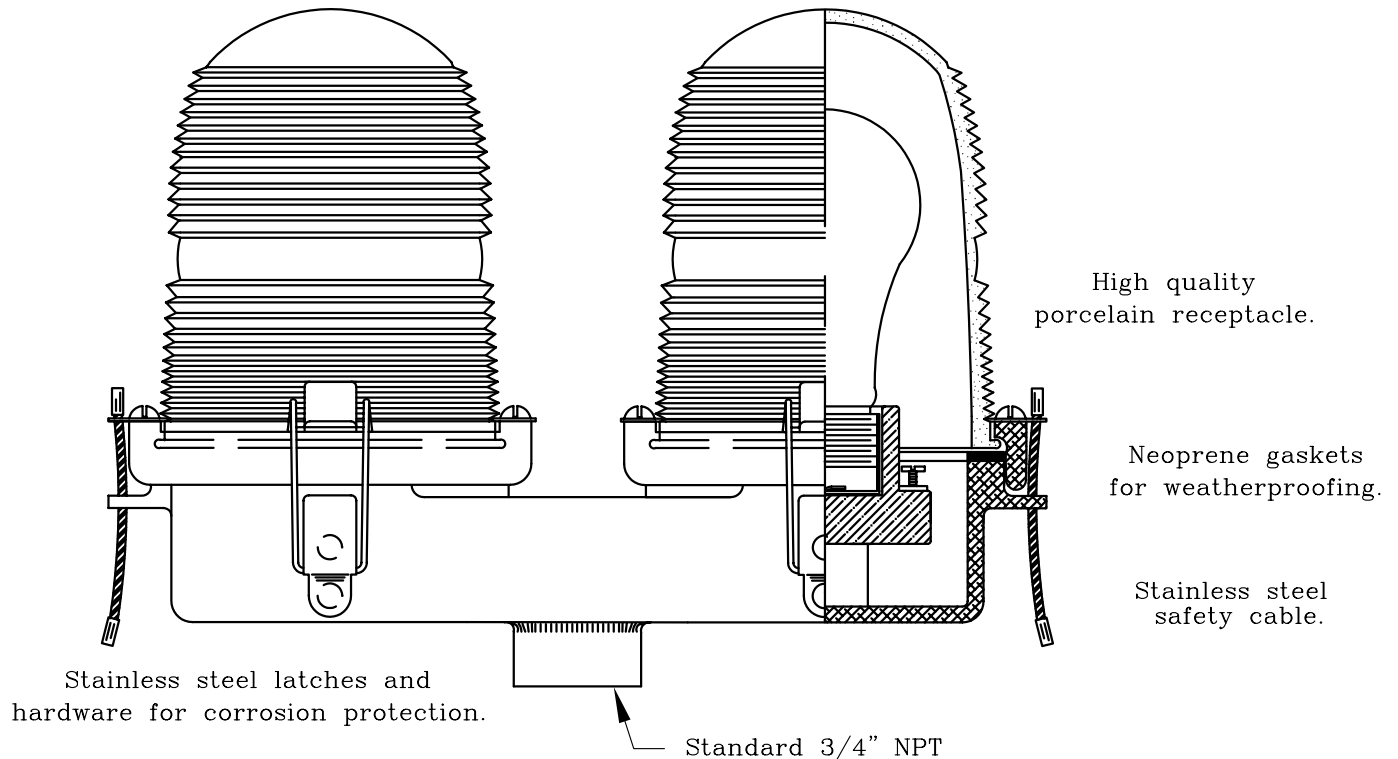

No special tools required for maintenance.

General Specifications

Height 7 inches (38.1 cm)
Weight 10 lbs. (4.5 kg)
Power 120 to 240V AC, 50 or 60Hz
Uses 116W, 120 or 240V bulbs
Bulbs sold separately

TWR Lighting, Inc.
4300 Windfern Rd. #100
Houston, Tx., 77041-8943
Phone: (713)973-6905
Fax: (713)973-9352

WEB SITE: <http://www.twrlighting.com>
©2003 TWR Lighting, Inc.

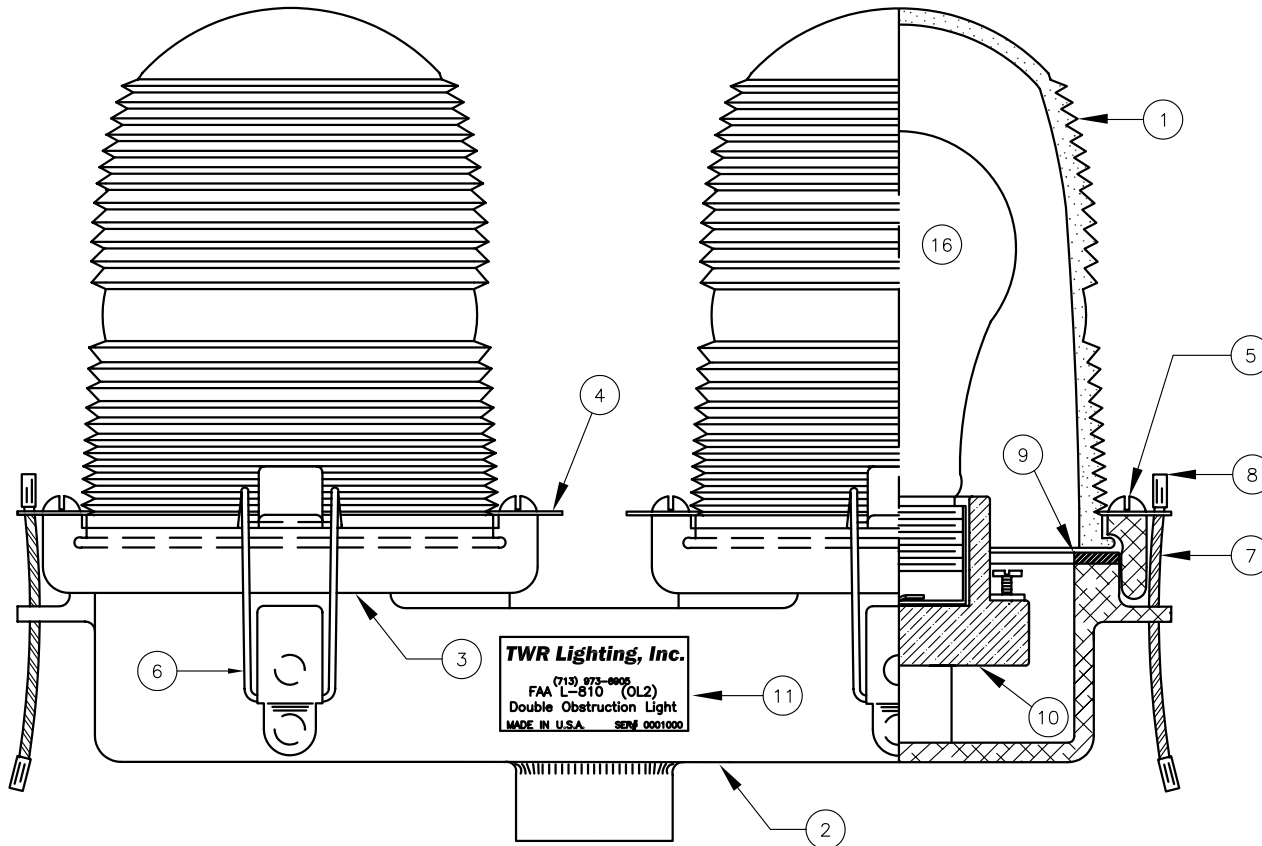

ITEM NO	QTY.	TWR PART NUMBER	DESCRIPTION
1	2	AP35222	RED SIDELIGHT GLASS
2	1	OL2C	DOUBLE SIDELIGHT BODY
3	2	106C	LENS HOLDER RING
4	4	12V245	OL LENS CLIP
5	4	832X14PH	8-32 X 1/4" PH S.S. SLOT
6	4	HC255SS	SIDELIGHT LATCHES
7	2	7X7SS	1/16 7 X 7 S.S. WIRE
8	4	A1A	STAKON CRIMP
9	2	OLG	OL GASKET
10	2	19062	SIDELIGHT RECEPTACLE
11	1	100324	OL2 SERIAL NUMBER LABEL
*	12	8	18PRSS 1/8 POP RIVETS
*	13	1	A314 3/4" CONDUIT LOCKNUT
*	14	4	104G WHITE TEFLON WASHER
*	15	4	832X34PH 8-32 X 3/4" S.S. PH SLOT
~	16	2	116A21TS 116W-120V LAMP (TYP.)

*=PART NOT SHOWN
 ~=PART SOLD SEPARATELY

NOTE:
 1. FAA APPROVED LIGHT USES THE 116A21TS LAMP.
 OTHER LAMPS ARE AVAILABLE TO MEET YOUR APPLICATION.

OL2

3/4" OL-2 SIDELIGHT
ASSEMBLY DETAIL (PART #OL2)

TWR Lighting, Inc.

APP'D	ENGINEER	CHK'D BY
DRAWN BY	E.A.SALAZAR	SHEET SIZE SHEET QTY. B 1 OF 1
DATE	10/30/96	SCALE N.T.S. DRAWING NO. 310

11/08/96 (A)	REVISED ITEM #15.#16
DATE:	LTR. REVISION

NOTE: This drawing is the property of TWR Lighting, Inc. All information contained herein that is not generally known shall be confidential except to the extent the information has been previously established. This drawing may not be reproduced, copied or used as the basis for manufacture or sale without written permission.

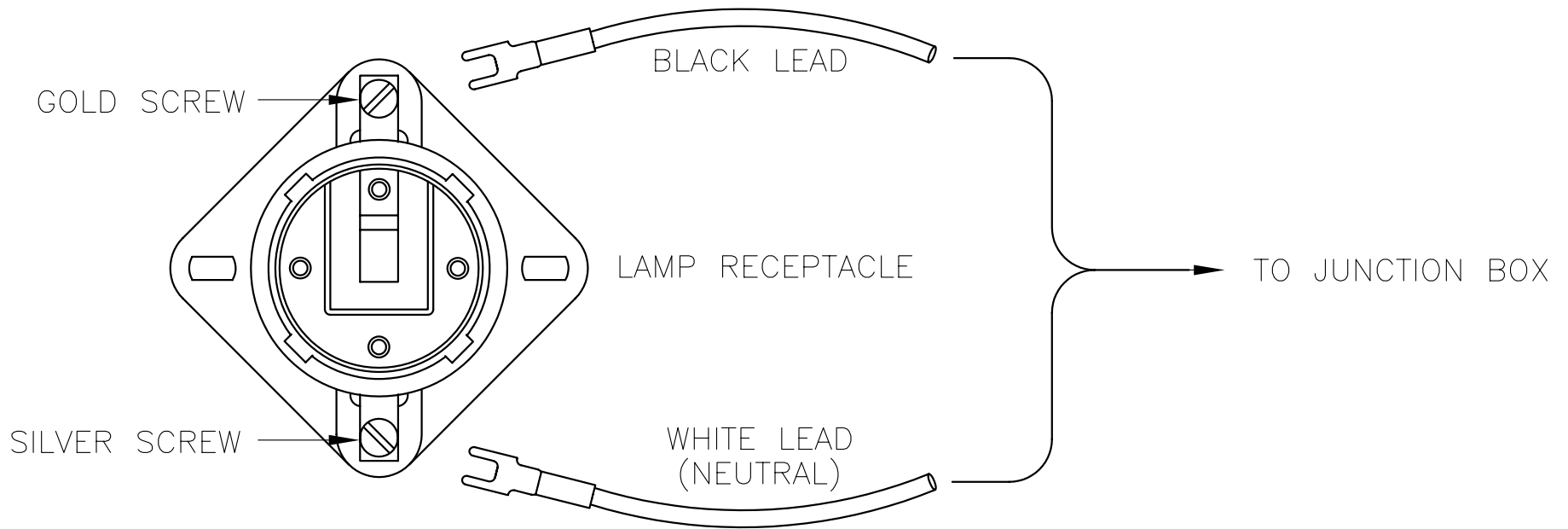

SIDELIGHT RECEPTACLE WIRING

TWR Lighting, Inc.

APP'D	ENGINEER	CHK'D BY	
DRAWN BY G.D. SEBEK		SHEET SIZE A	SHEET QTY. 1 OF 1
DATE 6/8/91	SCALE N.T.S.	DRAWING NO. 274-S	

7/2/98		GDS	CHANGED LABEL
DATE:	LTR.		REVISION

NOTICE: This drawing is the property of TWR Lighting, Inc. All information contained herein that is not generally known shall be confidential except to the extent the information has been previously established. This drawing may not be reproduced, copied or used as the basis for manufacture or sale without written permission.

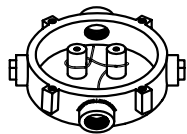
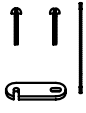
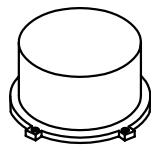
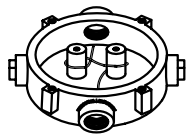
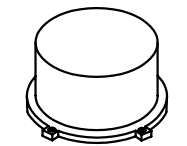

JB-5 AND JB-0
3/4" JUNCTION BOX

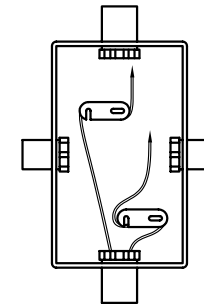
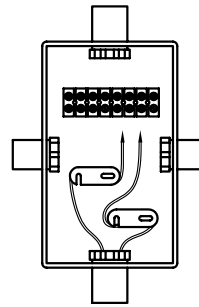

JB-8 AND JB-8SR
1" JUNCTION BOX

NOTES:

- 1) DRAWING ILLUSTRATES METHOD OF STRAIN RELIEVING WIRE. USE THIS METHOD ON ALL JUNCTION BOXES.
- 2) THE NATIONAL ELECTRICAL CODE-ARTICLE 300-19-B3 REQUIRES CONDUCTORS IN A VERTICAL CONDUIT BE SUPPORTED TO RELIEVE STRAIN ON TERMINAL BLOCK CONNECTIONS.
- 3) SKETCH ILLUSTRATES METHOD OF STRAIN RELIEVING A SINGLE CONDUCTOR. SEVERAL CONDUCTORS MAY BE GROUPED TOGETHER.
- 4) CONDUCTORS MAY BE MIXED BUT SHOULD NOT TAKE UP MORE THAN 40% OF CONDUIT'S INSIDE AREA.

USING THIS JUNCTION BOX METHOD SPACING IS 100 FEET MAXIMUM.

AWG WIRE SIZE	MAX. NUMBER WIRES IN 3/4" CONDUIT	MAX. NUMBER WIRES IN 1" CONDUIT	WIRE AREA SQ. INCHES	WEIGHT PER 100 FEET
12 THHN	16	26	0.0117	2.50
10 THHN	10	17	0.0184	4.10
8 THHN	6	9	0.0373	6.70
6 THHN	4	7	0.0519	10.30
4 THHN	2	4	0.0845	16.20

JUNCTION AND STRAIN RELIEF BOXES

TWR Lighting, Inc.

APP'D	ENGINEER	CHK'D BY
DRAWN BY	G.D.SFBEK	SHEET SIZE SHEET QTY. B 1 OF 1
DATE	7/26/93	SCALE N.T.S. DRAWING NO. 100089

9/29/00	(A)	UPDATED NOTES
DATE:	LTR.	REVISION

NOTICE: This drawing is the property of TWR Lighting, Inc. All information contained herein that is not generally known shall be confidential except to the extent the information has been previously established. This drawing may not be reproduced, copied or used as the basis for manufacture or sale without written permission.