

TWR Lighting, Inc.

Enlightened TechnologySM

4300 WINDFERN RD #100 HOUSTON TX 77041-8943

VOICE (713) 973-6905 FAX (713) 973-9352

web: www.twrlighting.com

IMPORTANT!!!

PLEASE TAKE THE TIME TO FILL OUT THIS FORM COMPLETELY. FILE IT IN A SAFE PLACE. IN THE EVENT YOU EXPERIENCE PROBLEMS WITH, OR HAVE QUESTIONS CONCERNING YOUR CONTROLLER, THE FOLLOWING INFORMATION IS NECESSARY TO OBTAIN PROPER SERVICE AND PARTS.

MODEL # AA0MTSS NEMA7 230V

SERIAL # _____

PURCHASE DATE _____

PURCHASED FROM _____

TWR Lighting, Inc.

Enlightened TechnologySM

AA0MTSS NEMA7 230V CONTROLLER

TABLE OF CONTENTS

1.0	GENERAL INFORMATION	1
2.0	INSTALLATION	2
2.1	MOUNTING THE CONTROL CABINET	2
2.2	EXTERNAL PHOTCELL WIRING	2
2.3	POWER WIRING	3
2.4	SIDELIGHT WIRING	3
2.5	SIDELIGHT ALARM WIRING	3
2.6	RESET BUTTON	5
3.0	THEORY OF OPERATION	5
3.1	POWER SUPPLY	5
3.2	SIDELIGHTS	5
3.3	OL2TR NEMA7	5
4.0	MAINTENANCE GUIDE	6
4.1	RED OBSTRUCTION LIGHTING	6
4.2	L-810 LAMP REPLACEMENT	6
4.3	CONTROLLER	6
4.4	PHOTOCELL	6
5.0	MAJOR COMPONENTS PARTS LIST	7
6.0	SUGGESTED SPARE PARTS LIST	8

WARRANTY & RETURN POLICY

RETURN MERCHANDISE AUTHORIZATION (RMA) FORM

TWR Lighting, Inc.

Enlightened TechnologySM

AA0MTSS NEMA7 230V CONTROLLER

APPENDIX

CHASSIS COMPONENT LAYOUT.....	1243-R
SCHEMATIC LAYOUT	1243-S
AO/4 LIGHT KIT.....	T-1294
OL2TRNEMA7 230V.....	1242-R

TWR Lighting, Inc.

Enlightened TechnologySM

AA0MTSS NEMA7 230V CONTROLLER

1.0 GENERAL INFORMATION

The TWR Lighting Inc. (TWR) Model AA0MTSS NEMA7 230V Controller is for applications of two (2) through sixteen (16) L-810 single obstruction light fixtures.

The obstruction lights burn steady. Each double fixture requires two (2) 116W, 230V bulbs, and each single requires only one (1).

An ON/OFF switch (SW1) is mounted at the front of the door of the unit. SW1 should always be in the “on” position, and the Indicator Pilot Light (PL1) will be illuminated green.

A photocell by-pass switch (SW2), mounted on front of the door of the unit, allows the controller to be turned on during daylight hours without covering the photocell. SW2 can be operated by turning it to the “on” position. Also, Indicator Pilot Light (PL2) will illuminate green.

NOTE: The enclosure provided is for Class I and II, Div. 1, and 2, Groups B, C, D, E, F, and G, as well as Class III, per NEC for hazardous locations (Article 500). Conduit seals are required within 18” from the enclosure on each conduit run (Article 501-5).

Power supplied to the controller shall be 230V, 50/60 Hz.

Controller functions that are monitored by remote alarms in the form of dry contact closures (Form C) are as follows:

POWER FAILURE	Monitors 230V AC to the controller. Alarms in the event of power failure, or tripped circuit breaker.
LIGHTS “ON”	Gives an indication whenever the controller is activated.
OBSTRUCTION LIGHTS	Will give an alarm when one (1) of the group of sidelights fails.

TWR Lighting, Inc.

Enlightened TechnologySM

AA0MTSS NEMA7 230V CONTROLLER

2.0 INSTALLATION

2.1 MOUNTING THE CONTROL CABINET

(Refer to Drawing 1243-R)

The power supply control cabinet can be located at the base of the structure, or outside an equipment building. Mounting footprints are shown on Drawing 1243-R. Power wiring to the control cabinet should be in accordance with local methods and National Electrical Codes (NEC).

2.1.1 The photocell should be mounted vertically on ¾" conduit so the photocell is above the control cabinet. Care must be taken to assure that the photocell does not "see" any ambient light that would prevent it from switching into the nightmode.

The wiring from the photocell, the service breaker, and the sidelights should enter the control cabinet through the bottom of the cabinet. Inside the cabinet, the connections will be made on the terminal strips and circuit breakers, which are located at the bottom of the chassis. These connections are made as follows:

2.2 EXTERNAL PHOTOCCELL WIRING

(Refer to Drawing 1243-R)

2.2.1 Connect the **BLACK** wire from the photocell to terminal block TB2, marked "L1."

2.2.2 Connect the **RED** wire from the photocell to terminal block TB2, marked "SSR."

2.2.3 Connect the **WHITE** wire from the photocell to terminal block TB2, marked "N."

TWR Lighting, Inc.

Enlightened TechnologySM

AA0MTSS NEMA7 230V CONTROLLER

2.3 POWER WIRING

(Refer to Drawing 1243-R)

2.3.1 Power wiring to the control cabinet should be in accordance with local methods and National Electrical Codes (NEC).

2.3.2 Circuit breaker needs to be rated at 25 amps.

2.3.3 Connect incoming 230V AC line to terminal block TB1, marked "L."

2.3.4 Connect the neutral wire(s) to one (1) of the terminal blocks on TB1, marked "N."

2.3.5 Connect the AC ground to the aluminum mounting plate.

NOTE: Make sure the controller, the photocell, and all of the light fixtures are properly grounded.

2.4 SIDELIGHT WIRING

(Refer to Drawing T-1293)

2.5 SIDELIGHT ALARM WIRING

(Refer to Drawings 1243-R and 1243-S)

Alarm relays K1 – K2, and alarm Modules M1 – M4, are provided for independent contact closures for: Power Failure; Lights "ON;" and "S1" – "S4" lamp burnout.

Alarm Wiring: To utilize all of the sidelight alarms, the customer will need six (6) pairs of wires to interface with the alarm device. One (1) wire from each of the six (6) pairs will terminate at the points marking common (C). The remaining wire from each pair will terminate as follows:

"S1" Lamp Burnout: Connect to Module M1, terminal T5, for normally open, (OR) terminal T6, for normally closed monitoring.

TWR Lighting, Inc.

Enlightened Technology^{S.M.}

AA0MTSS NEMA7 230V CONTROLLER

NOTE: It may be necessary to utilize a delay in the monitoring equipment connected to the dry contact alarm points in this controller, due to the varying tower heights.

“S2” Lamp Burnout: Connect to Module M2, terminal T5, for normally open, (OR) terminal T6, for normally closed monitoring.

“S3” Lamp Burnout: Connect to Module M3, terminal T5, for normally open, (OR) terminal T6, for normally closed monitoring.

“S4” Lamp Burnout: Connect to Module M4, terminal T5, for normally open, (OR) terminal T6, for normally closed monitoring.

Power Failure Alarm: Connect to relay K1, terminal #3, for normally open, or terminal #6, for normally closed monitoring.

Lights “ON” Alarm: Connect to relay K2, terminal #3, for normally open, or terminal #6, for normally closed monitoring.

TESTING To test alarms, follow the procedures using the “ohm” meter between alarm common and alarm points.

Power Failure Pull circuit breaker at electrical panel.

Lights “ON” Operate photocell by-pass switch (SW2) or cover the photocell.

Sidelights Trip circuit breaker on the controller panel for each circuit, then reset.

TWR Lighting, Inc.

Enlightened TechnologySM

AA0MTSS NEMA7 230V CONTROLLER

2.6 RESET BUTTON

The function of this button is to reset the K3 relay that controls the sidelight current sensors, and red failure light indicator, after a failure has occurred.

Once reset, if failure indicator comes on after about 15 seconds, it is determined a true failure exists in the fixtures. Check sidelight alarm contacts for cause of failure.

3.0 THEORY OF OPERATION

3.1 Power Supply

230V AC enters the controller from the circuit breaker panel with switch SW1 in the “on” position. Line sits at the PRD, waiting to be switched, and also keeps the power failure relay K1 energized. When the 102FAA-EP photocell is activated, line SSR energizes K2 “Lights On” relay. This can also be accomplished by using the photocell by-pass switch (SW2).

3.2 Sidelights

Lines LD1, and LD2 are being sent to Modules M1 – M4, through the toridal sensing coil, then to circuit breakers S1 – S4. Modules M1 – M4 are current sensors for the sidelights. If one (1) sidelight within the group burns out, then that particular module will send 230V out, converting it to DC voltage, and energizing the reset relay K3.

3.3 OL2TRNEMA7

(Refer to Drawings 1243-R and 1242-R)

S1/L enters through the bottom of the OL2TRNEMA7 230V from the Controller AA0MTSS NEMA7 230V “S1” circuit breaker. When Module M5, in the OL2TRNEMA7 230V, detects a main bulb failure, then that particular OL2TRNEMA7 230V will transfer voltage to the secondary bulb.

NOTE: It may be necessary to utilize a delay in the monitoring equipment connected to the dry contact alarm points in this controller, due to the varying tower heights.

TWR Lighting, Inc.

Enlightened TechnologySM

AA0MTSS NEMA7 230V CONTROLLER

4.0 MAINTENANCE GUIDE

4.1 RED OBSTRUCTION LIGHTING

The only required maintenance needed to be performed is replacement of the lamps in the L-810 fixtures. Lamps should be replaced after being operated for not more than 75% of the rated life or immediately upon failure as per FAA Advisory Circular 70/7460-1K. By following these instructions, maximum safety and performance can be achieved.

TOOLS REQUIRED: NONE

4.2 L-810 LAMP REPLACEMENT

4.2.1 Loosen the 1/4 – 20 set screw.

4.2.2 Lift the lens up and over the lamp, letting the lens hang from the safety chain.

4.2.3 Unscrew the lamp counter-clockwise and remove.

4.2.4 Install the new lamp by screwing the lamp clockwise.

4.2.5 Reinstall the lens, making sure it is seated properly on the base.

4.2.6 Retighten the 1/4 – 20 set screw.

4.3 CONTROLLER

No scheduled maintenance is required. Perform on an as needed basis.

4.4 PHOTOCCELL

The photocell is a sealed unit. No maintenance is needed or required other than replacement as necessary.

TWR Lighting, Inc.

Enlightened TechnologySM

AA0MTSS NEMA7 230V CONTROLLER

5.0 MAJOR COMPONENTS PARTS LIST

QUANTITY	PART NUMBER	DESCRIPTION
1	102FAA-EP	Explosion Proof Photocell
1	EXB16166N34	Explosion Proof Enclosure
4	PB27E122	Octal Sockets (K1 – K3)
7	8WA1204	Terminal Blocks (TB1, and TB2)
4	S261D6	6 amp Circuit Breaker (S1 - S4)
2	8WA1808	End Stop
2	9KE – 240V	SPDT 240V AC Relay (K1, and K2)
4	SCR630T	240V Current Sensors (M1 – M4)
1	KRPA5DG24V	DPDT Relay 240V DC (K3)
1	PRD7AYO-240V	240V Contact Relay
2	TERMBLK141-8	Terminal Block (TB3, and TB5)
2	GOB3G23CN34	Green Indicators NEMA 7 (PL1, and PL2)
1	GO1-KX3CN34	Reset/Momentary Switch (SW3)
2	GO52A3FN34	SPSP Switch NEMA 7 (SW1, and SW2)
1	GOB3R23CN34	Red Indicator NEMA 7 (PL3)
1	TERMBLK141-7	Terminal Block (TB4)
4	SCD2500V2A	3W2.5 Rectifier (D1, D2, D3, and D4)
1	STB99013	47uf 160V Electrolytic Capacitor (C1)
3	STA40005	MIL Resister 5k 50W (R1, R2, and R3)
2	STA40008	MIL Resister 1k 50W (R4, and R5)

TWR Lighting, Inc.

Enlightened TechnologySM

AA0MTSS NEMA7 230V CONTROLLER

6.0 SUGGESTED SPARE PARTS LIST

QUANTITY	PART NUMBER	DESCRIPTION
2	9KE – 240V	SPDT 240V Relay (K1, and K2)
1	SCR630T	240V Current Sensors (M1 – M4)
1	KRPA5DG24V	DPDT 24V Relay (K3)
1	PRD7AYO-240V	240V Contact Relay

TWR Lighting, Inc.

Enlightened TechnologySM

AA0MTSS NEMA7 230V CONTROLLER

Warranty & Return Policy

TWR Lighting, Inc. (“TWR”) warrants its products (other than “LED Product”) against defects in design, material (excluding incandescent bulbs) and workmanship for a period ending on the earlier of two (2) years from the date of shipment or one (1) year from the date of installation.

TWR Lighting, Inc. (“TWR”) warrants its “LED Product” against defects in design, material and workmanship for a period of five (5) years from the date of shipment. TWR, at its sole option, will, itself, or through others, repair, replace or refund the purchase price paid for “LED Product” that TWR verifies as being inoperable due to original design, material or workmanship. All warranty replacement “LED Product” is warranted only for the remainder of the original warranty of the “LED Product” replaced. Replacement “LED Product” will be equivalent in function, but not necessarily identical, to the replaced “LED Product.”

TWR Lighting, Inc. (“TWR”) warrants its “LED Product” against light degradation for a period of five (5) years from the date of installation. TWR, at its sole option, will, itself, or through others, repair, replace or refund the purchase price paid for “LED Product” that TWR verifies as failing to meet 70% of the minimum intensity requirements as defined in the FAA Advisory Circular 150/5345-43E dated 10/19/95. All warranty replacement “LED Product” is warranted only for the remainder of the original warranty of the “LED Product” replaced. Replacement “LED Product” will be equivalent in function, but not necessarily identical, to the replaced “LED Product.”

Replacement parts (other than “LED Product”) are warranted for 90 days from the date of shipment.

Conditions not covered by this Warranty, or which might **void** this Warranty are as follows:

- Improper Installation or Operation
- Misuse
- Abuse
- Unauthorized or Improper Repair or Alteration
- Accident or Negligence in Use, Storage, Transportation, or Handling
- Any Acts of God or Nature
- **Non-OEM Parts**

The use of non-OEM parts or modifications to original equipment design will void the manufacturer warranty and could invalidate the assurance of complying with FAA requirements as published in Advisory Circular 150/5345-43.

Field Service – Repairs are warranted for 90 days from the date of service, except where TWR has made recommendations that were not adhered to that may cause premature failure on previous repairs. Labor, Travel, and Tower Climb are not covered under warranty. Customer shall be obligated to pay for all incurred charges not related to warranty. All warranty repairs are performed by trained TWR personnel, or dispatched through an extensive network of certified and insured Service Representatives.

TWR Lighting, Inc.

Enlightened TechnologySM

AA0MTSS NEMA7 230V CONTROLLER

Warranty & Return Policy (continued)

Return Policy

Return Terms – You must first contact our Customer Service Department at **713-973-6905** to acquire a Return Merchandise Authorization (RMA) number in order to return the product(s). Please have the following information available when requesting an RMA number:

- The contact name and phone number of the tower owner
- The contact name and phone number of the contractor
- The site name and number
- The part number(s)
- The serial number(s) (if any)
- A description of the problem
- The billing information
- The Ship To address

This RMA number must be clearly visible on the outside of the box. If the RMA number is not clearly labeled on the outside of the box, your shipment will be refused. Please ensure the material you are returning is packaged carefully. **The warranty is null and void if the product(s) are damaged in the return shipment.**

All RMAs must be received by TWR LIGHTING, INC., 4300 WINDFERN RD #100, HOUSTON TX 77041-8943, within 30 days of issuance.

Upon full compliance with the Return Terms, TWR will replace, repair and return, or credit product(s) returned by the customer. It is TWR's sole discretion to determine the disposition of the returned item(s).

Replacements – Replacement part(s) will be shipped and billed to the customer for product(s) considered as Warranty, pending return of defective product(s). When available, a certified reconditioned part is shipped as warranty replacement with a Return Merchandise Authorization (RMA) number attached. Upon receipt of returned product(s), inspection, testing, and evaluation will be performed to determine the cause of defect. The customer is then notified of the determination of the testing.

- Product(s) that is deemed defective and/or unrepairable and covered under warranty - a credit will be issued to the customer's account.
- Product(s) found to have no defect will be subject to a **\$60.00 per hour testing charge (1 hour minimum), which will be invoiced to the customer.** At this time the customer may decide to have the tested part(s) returned and is responsible for the return charges.
- Product(s) under warranty, which the customer does not wish returned, the customer will be issued a credit against the replacement invoice.

TWR Lighting, Inc.

Enlightened TechnologySM

AA0MTSS NEMA7 230V CONTROLLER

Warranty & Return Policy (continued)

Repair & Return – A Return Merchandise Authorization (RMA) will be issued for all part(s) returned to TWR for repair. Upon receipt of returned product(s), inspection, testing and evaluation will be performed to determine the cause of defect. The customer is then notified of the determination of the testing. If the returned part(s) is deemed unrepairable, or the returned part(s) is found to have no defect, the customer will be subject to a **\$60.00 per hour testing charge (1 hour minimum), which will be invoiced to the customer.** Should the returned parts be determined to be repairable, a written estimated cost of repair will be sent to the customer for their written approval prior to any work being performed. In order to have the tested part(s) repaired and/or returned, the customer must issue a purchase order and is responsible for the return shipping charges.

Return to Stock – Any order that is returned to TWR for part(s) ordered incorrectly by the customer, or unneeded upon receipt, the customer is required to pay a **20% restocking fee.** A credit will be issued once it is determined that the Return Terms are met.

Credits – Credits are issued once it is determined that all of the Warranty and Return Terms are met. All credits are processed on Fridays. In the event a Friday falls on a Holiday, the credit will be issued on the following Friday.

Freight – All warranty replacement part(s) will be shipped via ground delivery and paid for by TWR. Delivery other than ground is the responsibility of the customer.

REMEDIES UNDER THIS WARRANTY ARE LIMITED TO PROVISIONS OF REPLACEMENT PARTS AND REPAIRS AS SPECIFICALLY PROVIDED. IN NO EVENT SHALL TWR BE LIABLE FOR ANY OTHER LOSSES, DAMAGES, COSTS OR EXPENSES INCURRED BY THE CUSTOMER, INCLUDING, BUT NOT LIMITED TO, LOSS FROM FAILURE OF THE PRODUCT(S) TO OPERATE FOR ANY TIME, AND ALL OTHER DIRECT, INDIRECT, SPECIAL, INCIDENTAL, OR CONSEQUENTIAL DAMAGES, INCLUDING ALL PERSONAL INJURY OR PROPERTY DAMAGE DUE TO ALLEGED NEGLIGENCE, OR ANY OTHER LEGAL THEORY WHATSOEVER. THIS WARRANTY IS MADE BY TWR EXPRESSLY IN LIEU OF ALL OTHER WARRANTIES, WHETHER EXPRESSED OR IMPLIED. WITHOUT LIMITING THE GENERALITY OF THE FORGOING, TWR MAKES NO WARRANTY OF MERCHANTABILITY OR FITNESS OF THE PRODUCT(S) FOR ANY PARTICULAR PURPOSE. TWR EXPRESSLY DISCLAIMS ALL OTHER WARRANTIES.

TWR Lighting, Inc.

Enlightened Technology^{S.M.}

AA0MTSS NEMA7 230V CONTROLLER

RETURN MERCHANDISE AUTHORIZATION (RMA) FORM

RMA#: _____ **DATE:** _____

CUSTOMER: _____

CONTACT: _____ **PHONE NO.:** _____

ITEM DESCRIPTION (PART NO.): _____

MODEL NO.: _____ **SERIAL NO.:** _____

ORIGINAL TWR INVOICE NO.: _____ **DATED:** _____

DESCRIPTION OF PROBLEM: _____

SIGNED: _____ **DATE NEEDED:** _____

RETURN ADDRESS: _____

TWR Lighting, Inc.

Enlightened Technology^{S.M.}

AA0MTSS NEMA7 230V CONTROLLER

RETURN MERCHANDISE AUTHORIZATION (RMA) FORM

RMA#: _____ **DATE:** _____

CUSTOMER: _____

CONTACT: _____ **PHONE NO.:** _____

ITEM DESCRIPTION (PART NO.): _____

MODEL NO.: _____ **SERIAL NO.:** _____

ORIGINAL TWR INVOICE NO.: _____ **DATED:** _____

DESCRIPTION OF PROBLEM: _____

SIGNED: _____ **DATE NEEDED:** _____

RETURN ADDRESS: _____

MOUNTING DIMENSIONS

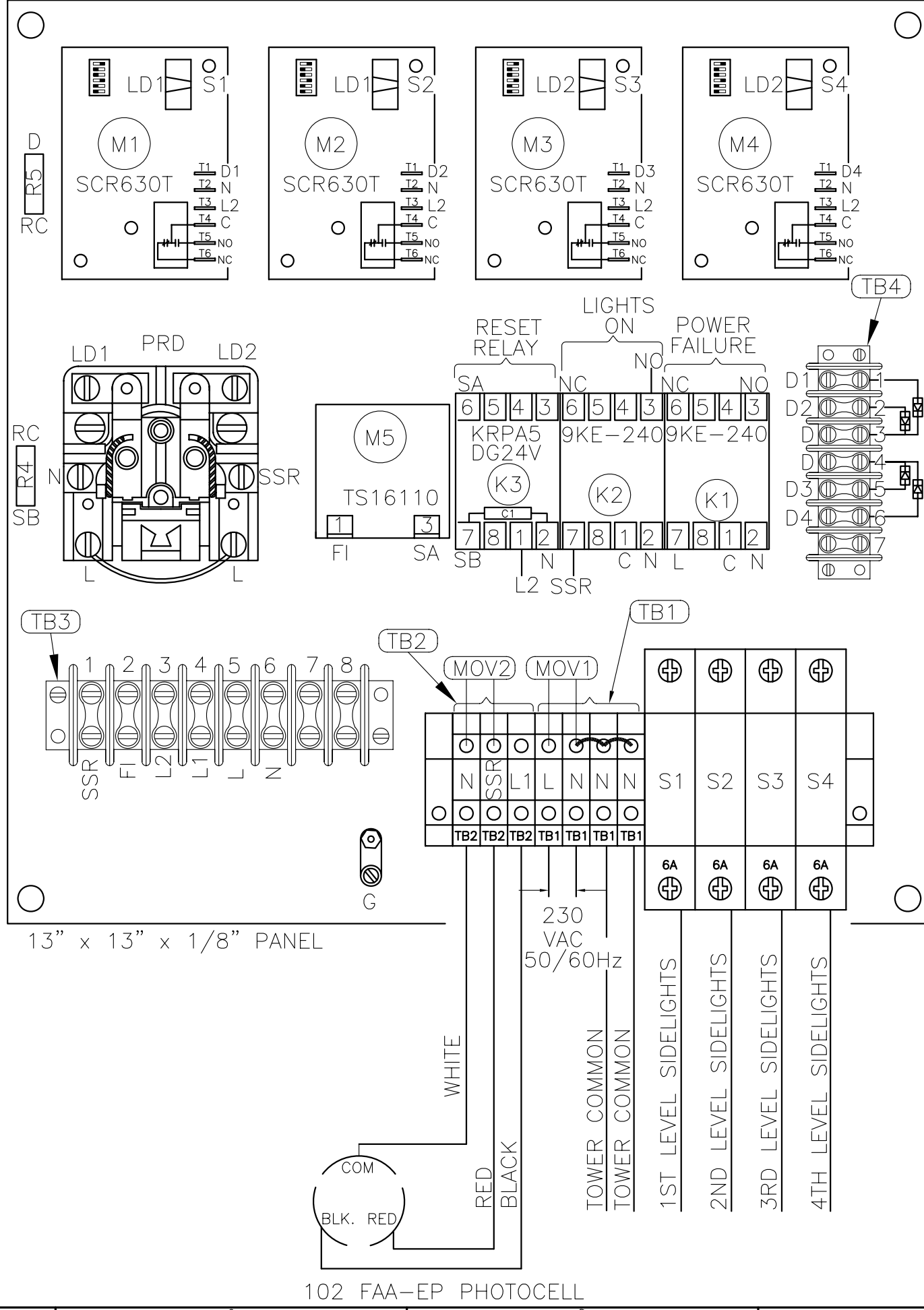
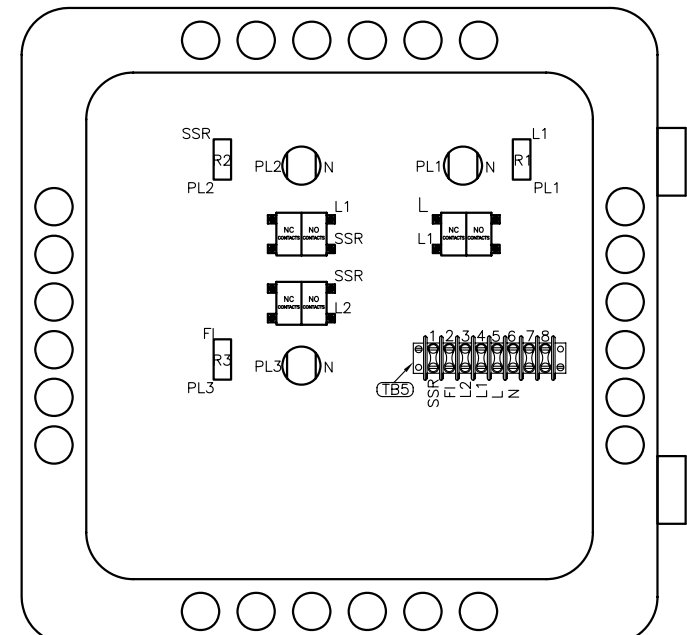
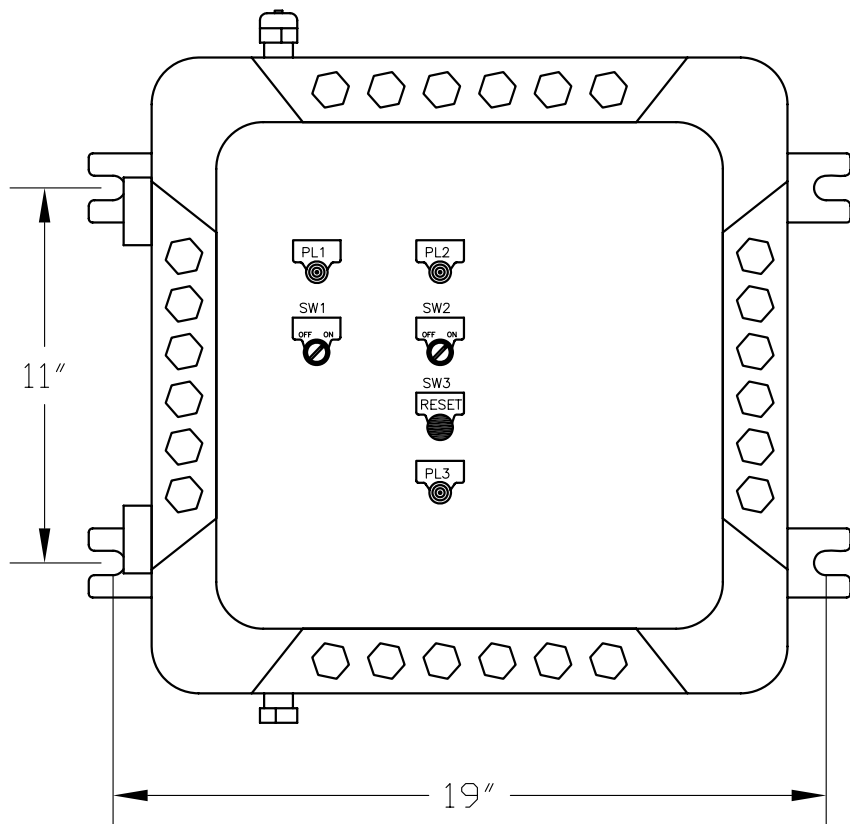

CUSTOMER ALARM POINTS

- C=ALARM COMMON
- NC=NORMALLY CLOSED
- NO=NORMALLY OPEN
- K1=POWER FAILURE
- K2=LIGHTS ON
- M1-M4=SIDE LIGHTS FAILURE

NOTES:

- 1) WIRES ARE CONNECTED LETTER TO LETTER. (EXAMPLE) L1 TO L1 TO L1.
- 2) THE ENCLOSURE PROVIDED IS FOR CLASS I, DIV. I AND II GROUPS B, C & D: CLASS II, DIV. I AND II GROUPS E, F & G: AS WELL AS CLASS III PER UL APPROVALS.

AAOMTSSNEMA7230V CONTROLLER
CHASSIS LAYOUT 230V 50/60HZ

TWR Lighting, Inc.

APP'D	ENGINEER	CHK'D BY
DRAWN BY J.L.BUSTAMANTE		SHEET SIZE SHEET QTY. B 1 OF 1
DATE 06/27/07	SCALE N.T.S.	DRAWING NO. 1243-R

NOTICE: This drawing is the property of TWR Lighting, Inc. All information contained herein that is not generally known shall be confidential except to the extent the information has been previously established. This drawing may not be reproduced, copied or used as the basis for manufacture or sale without written permission.

102 FAA-EP PHOTOCCELL

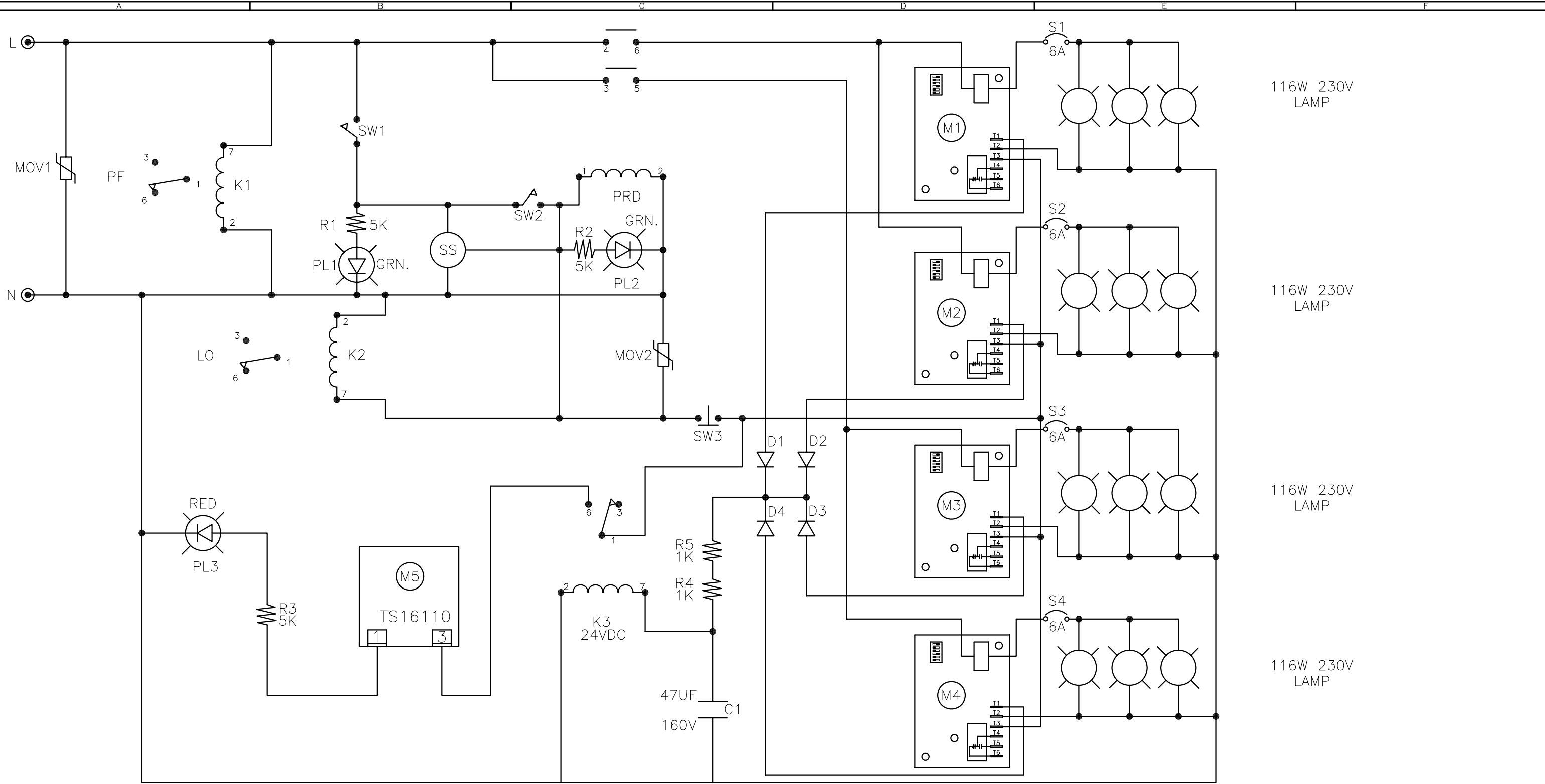

116W 230V LAMP

116W 230V LAMP

116W 230V LAMP

116W 230V LAMP

AAOMTSSNEMA7230V SCHEMATIC
230V 50/60HZ

PROD DEPT	TWR Lighting, Inc. <i>Enlightened Technology</i>				
SERV DEPT					
ENGINEER					
DRAWN BY	J.L.BUSTAMANTE	SHEET SIZE	B	SHEET QTY.	1 OF 1
DATE	06/28/07	SCALE	N.T.S.	DWG. NO.	1243-S

The use of non-OEM parts or modifications to original equipment design will void the manufacturer warranty and could invalidate the assurance of complying with FAA requirements as published in Advisory Circular 150/5345-43.
NOTICE: The drawings and photographic images contained herein are the sole property of TWR Lighting, Inc. All information contained herein that is not generally known shall be considered confidential except to the extent the information has been previously established. The drawings and photographic images contained herein may not be reproduced, copied or used as the basis for manufacture or sale or promotion or any other purpose without the expressed written permission of TWR Lighting, Inc.

BILL OF MATERIALS

ITEM NO.	QTY.	TWR PART NO.	DESCRIPTION
1	1	AAOMTSSNEMA7	AAOMTSS NEMA 7 CONTROLLER
2	3	OL2	DOUBLE OBSTRUCTION LIGHT
3	9	OL1	3/4" OBSTRUCTION LIGHT
4	15	116A21TS230V	116 WATT 230 VOLT LAMP
* 5	12	JB5	3/4" JUNCTION BOX
6	24	EN1246	3/4" TO 1" MALE ENLARGER

* = NOT SHOWN

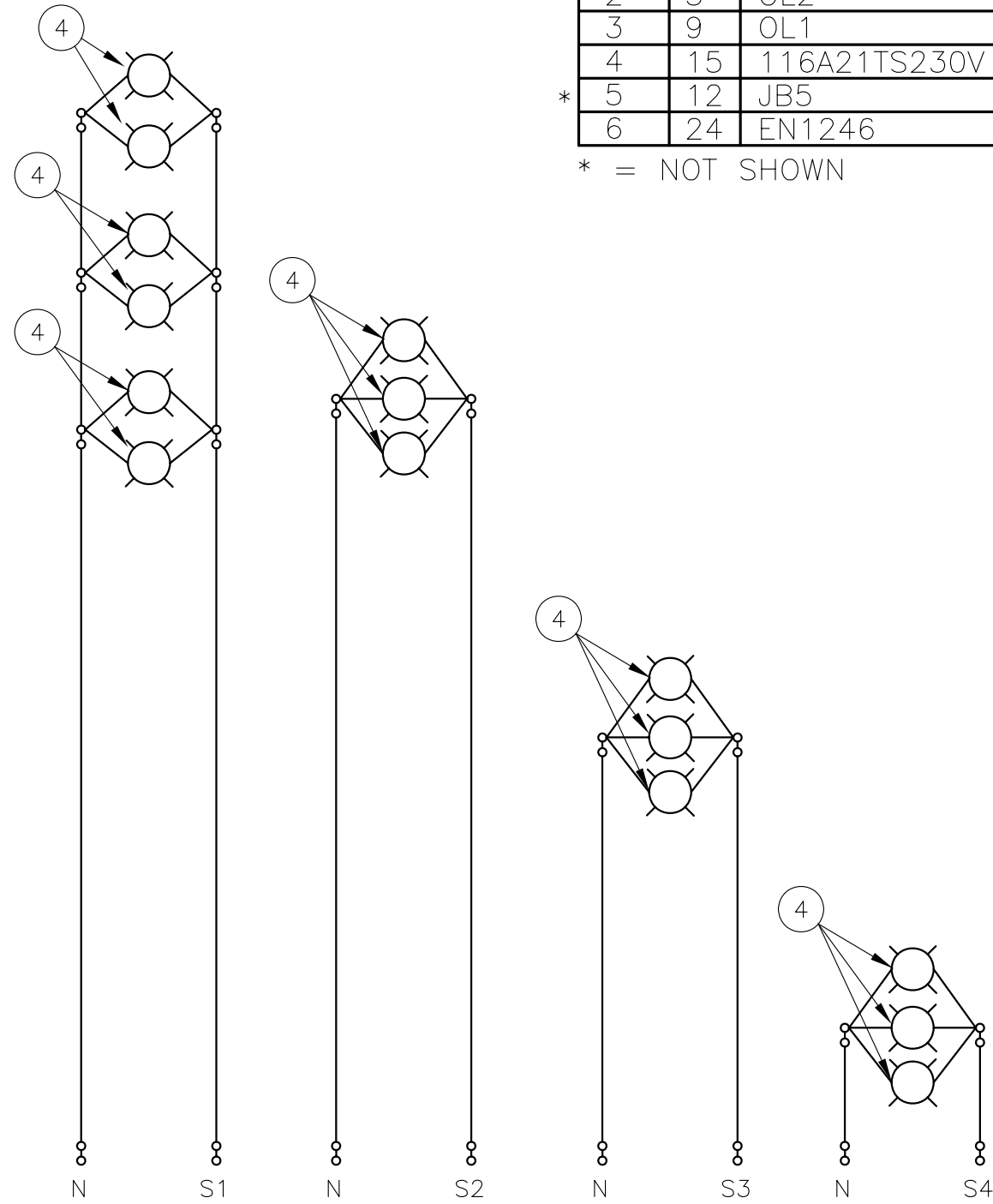
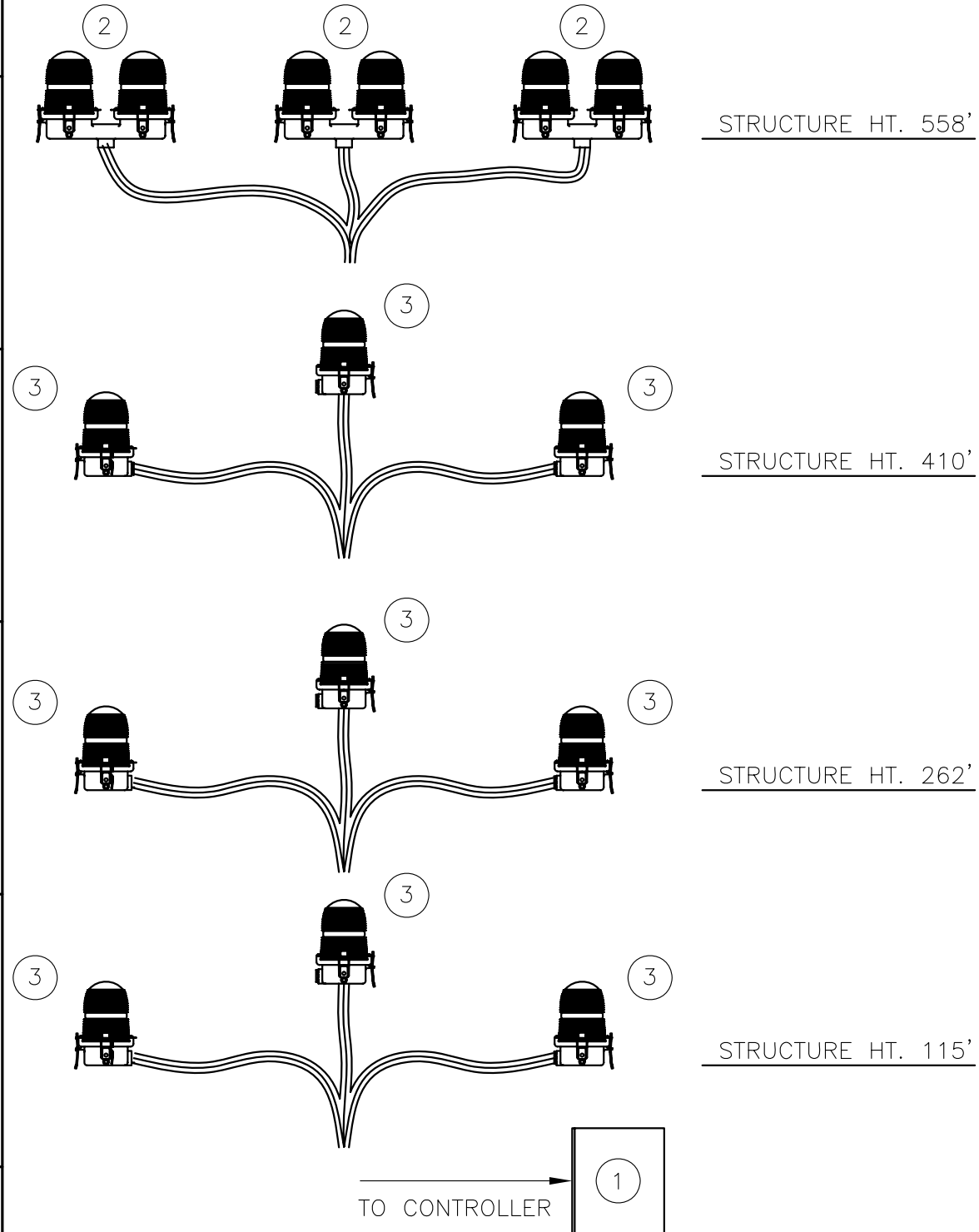

NOTES:
1. TWR IS NOT SUPPLYING THE HARDWARE FOR THE KIT.

230V

A0/4 LIGHTING KIT

APP'D	TWR Lighting, Inc. <i>Enlightened Technology</i>		
CHK'D BY			
ENGINEER			
DRAWN BY J.L.BUSTAMANTE	SHEET SIZE B	SHEET QTY. 1 OF 1	DWG. NO. T1294
DATE 07/02/07	SCALE N.T.S.		

The use of non-OEM parts or modifications to original equipment design will void the manufacturer warranty and could invalidate the assurance of complying with FAA requirements as published in Advisory Circular 150/5345-43.
NOTICE: The drawings and photographic images contained herein are the sole property of TWR Lighting, Inc. All information contained herein that is not generally known shall be considered confidential except to the extent the information has been previously established. The drawings and photographic images contained herein may not be reproduced, copied or used as the basis for manufacture or sale or promotion or any other purpose without the expressed written permission of TWR Lighting, Inc.

